

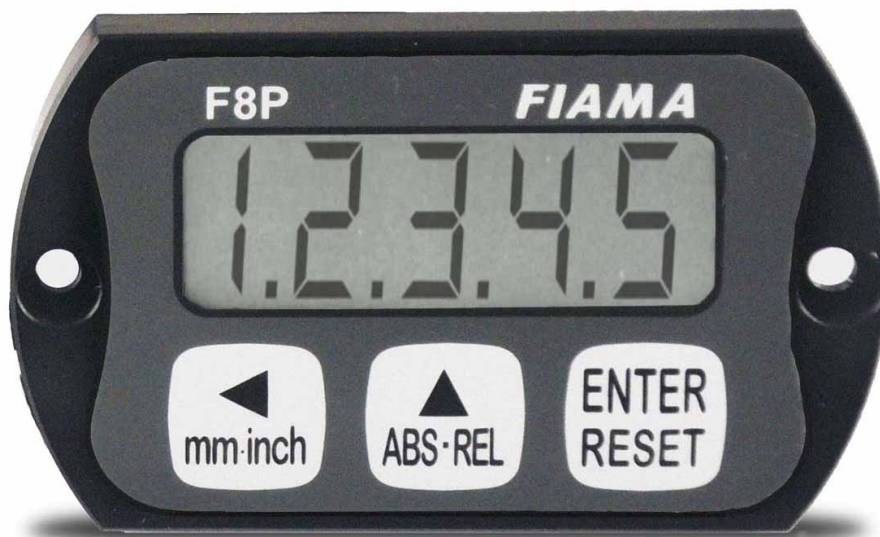

COMPANY WITH
QUALITY SYSTEM
CERTIFIED BY DNV GL
= ISO 9001:2015 =



USER'S MANUAL AND MAINTENANCE

DISPLAY PANEL MOUNT FOR MAGNETIC BAND
WITH BATTERY POWER SUPPLY TYPE "F8P-"

Manual purpose

This manual has been designed by the Manufacturer to provide the necessary information regarding the instrument F8P_ to those who are authorized to carry out safely its installation, maintenance, dismantling and disposal. All the necessary information for the buyers and planners can be found in the Sales catalogue. Other than adopting good technical construction methods, the information should be read carefully and strictly applied. Inobservance of this information could cause risks for the health and safety of people and economical damage. This information, provided by the Manufacturer in the original language(Italian) is also available in other languages to satisfy legislative and/or commercial needs. This manual must be kept in good conditions by a responsible person in an ideal place so that it is always available for consultation. In case this manual is lost or deteriorates, a replacement should be requested directly from the manufacturer quoting the manual's code. This manual reflects the state of skill of the instrument at the time of input on the market: however the manufacturer reserves the right to make changes, add or improve the manual without giving any reason to hold the present manual inadequate.

Identification of the equipment

The identification plate represented is applied on the instrument.

To find out the identification code of the instrument, consult the sales catalogue.

Environmental conditions

Temperature setting: min. 0°C, max. + 50°C.

It is forbidden to use the instrument other than its specific use and in potentially explosive conditions or where anti- explosive elements are used.

Storage

Here below are some references to be followed for the storage of the instrument.

Avoid environments with excessive humidity and those exposed to bad weather (avoid open areas). Avoid putting the instrument directly on the ground. Store the instrument in its original packing.

Conformity declaration and EC marking

The instrument answers to the following Communitarian Directives:

2014/30/EU Electromagnetic compatibility, 2011/65/EU RoHS.

Maintenance

The instrument does not needs a particular maintenance except cleaning to do only with a soft cloth dampen with ethylic alcohol or water. Do not use hydrocarbon solvents (petrol, diluents, etc.): the using of these products could affect the proper functioning of the instrument.

Reparations should be done only and exclusively at the FIAMA technical assistance centre.

Calibrations and tests

It is advisable to calibrate the instrument periodically, once every working year.

To do the calibration, follow the calibration procedure indicated in the present manual.

Assistance request procedure

For any kind of technical assistance request, contact the sales department of the Manufacturer directly indicating the information given on the identification plate, the number of hours used and the type of defect.

Manufacturer's responsibility

The manufacturer declines any responsibility in case of :

- Using the instrument contrary to the national safety and accident-prevention laws.
- Wrong installation, inobservance or wrong procedures of the instructions provided in the present manual.
- Defective electrical power supply.
- Modifications or tampering.
- Operations carried out by untrained or unqualified staff.

The safety of the instrument also depends on the strict observance of the procedures indicated in the manual: always operate the instrument in its functioning capacity and carry out a careful routine maintenance.

- All phases of inspection and maintenance should be done by qualified staff.

- The configurations provided in the manual are the only ones permitted.
- Do not try to use it anyway contrary to the indications provided.
- The instructions in this manual do not substitute but accomplish the obligations of the current legislation regarding the safety laws.

Installation

Before installing the instrument, read the following warnings:

- Connect the instrument strictly following the instructions of the manual.
- It is the responsibility of the user to check, before using, the correct settings of the parameters of the instrument to avoid damage to persons or things.
- The instrument CANNOT function in a dangerous environment (inflammable or explosive).
- The unit has sensible parts to electrostatic charge, therefore the handling of the inner electronic cards has to be carried out with appropriate care to avoid permanent damages.

Description

The F8P is a display unit with integrated position sensor, in combination with the P50 magnetic band, is a complete system to measure linear movements.

The display has five digits plus sign (range from -999999 up to +999999). The digits are 10mm high to allow excellent readability also at a distance.

It is possible to select the counting direction, the number of decimal places, and the units (mm or inches). The displayed value can be corrected with a multiplication factor, with values between 0.00001 and 999999.

The instrument can count in absolute mode or relative mode by pressing the corresponding button. Also, it is possible to set a preset value which can be activated by pressing the corresponding button.

The electronics are seated in a smart and strong black anodized aluminum case.

The display can be fixed quickly and easily using the two holes on the housing.

The unit is powered by a ½AA 3.6V battery which lasts approximately 4 years and when the battery is almost exhausted, an icon will appear to advise the operator to substitute it. This does not effect the configuration parameters and also the correct measurement is maintained if the magnetic band is not moved during this operation.

Programming

To step into the parameter programming press key ▲ and on the display appears **PASS**, now press 2 times key RESET and appear 4 zeroes, the first on the right is blinking, with keys ▲ (digit increase) and ◀ (digit selection), set out password **0273** and confirm with RESET. In case of wrong set-out of password it goes out of the programming. The parameters that have to be set can be run with key ▲ and in order of appearance they are:

- ▣ **15** value to be displayed for 10mm of sensor displacement,
- ndEC** number of decimal digits,
- tRSt I** keys opening mode
- d IrCOn** count direction,

To enter into the modification of the selected parameter press two times RESET (one time displays only the value) and with keys ▲ and ◀ set the wanted value to be confirmed with RESET.

To go out of the programming press ◀.

▣ **15** Value to be displayed for 10 mm of sensor displacement

This parameter together with the following allows the programming of the value on the display for a certain displacement of the sensor. It means that is necessary to set the value which has to be displayed corresponding to a displacement of the sensor on the magnetic band of 10mm.

The Factory value is VISUAL=10.0, which is the necessary value to read the displacement in millimetres with decimal resolution.

The range allowed is from 0,00001 to 999999 with setting of decimal point position that is, after programming of the last digit on the left, pressing key ◀ will blink the decimal pinpoint and with key ▲ it can be moved to the wanted position. Confirm with RESET.

ndEC Number of decimal digits

It is the number of decimal digits to visualize on the display, range allowed from 0 to 4.

Example: for every 10mm of linear displacement it is necessary to display 12.3456 with only two decimal places: Set $u\ 15=12,3456$ and $ndEC=2$

FAST / Keys opening mode

This parameter programmes the functions linked to the keys.

The value to set is a number of three digits so each key corresponds to a digit; the digit on the right stands for setting of key RESET, the digit in the middle stands for key ▲ while the last digit on the left stand for key ◀.

The values allowed are the following:

VALUE	◀	▲	ENTER/RESET
0	Not active	Not active	Not active
1	mm/inch conversion	abs/rel measurement	Reset
2	Not active	Not active	Preset
3	Not active	Not active	Fast Preset
4	Not active	Not active	Change of origin 0,1,2
5	Not active	Not active	Offset
6	Not active	Not active	Fast Offset
7	Not active	Not active	Delayed reset * (after 3s)
8	Not active	Not active	Delayed preset * (after 3s)

* Delayed means that to activate the function (reset or preset), it is necessary to keep **ENTER/RESET** pressed for approximately 3 s.

Reset: reset function of the displayed value; after pressing **ENTER/RESET**, the displayed value is set to zero.

Preset: preset function of the displayed value; after pressing **ENTER/RESET**, the displayed value becomes equal to the value in the **Pr5t** parameter, which can be set immediately after **FAST** (when the digit on the right is set to 2).

Fast Preset: the fast setting of the displayed value on the display; after pressing **ENTER/RESET** **Pr5t** appears and pressing 2 times **ENTER/RESET** it is possible to set the value directly (use ▲ and ◀ and then confirm with **ENTER/RESET**). This function is useful when the displayed value must be corrected often.

Origin change (correction of the displayed value for tool changes): with this function 3 different origins (0,1,2) can be set and with **ENTER/RESET** it is possible to switch from one origin to another. After setting 4 in the first digit on the right of the **FAST** parameter, **Pr50** will appear and after pressing 2 times **ENTER/RESET** it is possible to set the nominal value for tool 0 (for example the radius of cutter 0), which is then confirmed by pressing **ENTER/RESET**.

Now **Pr51** will appear which is the nominal value for tool 1 (for example the radius of cutter 1): set the correct value and confirm with **ENTER/RESET**.

Finally **Pr52** will appear which is the nominal value for tool 2 (for example the radius of cutter 2): set the correct value and confirm with **ENTER/RESET**.

In practice *Pr50*, *Pr51*, and *Pr52* are the nominal values associated to the three different tools which are used.

As a special case, if *Pr50* is set to zero, *Pr51* and *Pr52* are the values to display in origin 1 and in origin 2 respectively.

ABS/REL function: Enables passing from an absolute to relative value; after pressing ▲, the displayed value is temporarily set to zero to measure a relative motion of the transducer. On the display the REL icon indicates that the current display is relative to the reference point that has just been created. Pressing again ▲ causes the absolute value to be displayed and the ABS icon will appear.

mm/inch conversion: Pressing ◀ converts the measurement from millimeters to inches and back. When in inch mode, the INCH icon will appear and the displayed value will have an additional decimal place. When the parameter *ndEC*=4 the mm/inch conversion is not available.

Offset: This parameter is added to or subtracted from the displayed value to correct it in case, for example, of a tool change or to compensate tool wear. After setting a positive offset value, the displayed value will be the measured value plus the offset value. After setting a negative offset value, the displayed value will be the measured value minus the offset value.

Fast Offset: After pressing ENTER/RESET, *OFFSt* appears and by pressing two times ENTER/RESET it is possible to set directly the value to be displayed (use buttons ▲ ◀ and confirm with ENTER/RESET). This function is useful if it is necessary to correct often the displayed value.

▣ Ir Count direction

Set out the count direction of the display, range allowed 0 or 1.

Adjustment of displayed value

After the installation of instrument on the machine and setting of all parameters, in order to visualize on the display the correct value it is necessary to carry out the reset or preset.

Position the shaft in a point in which the correct measure that has to be visualized is known exactly (for example the stroke end point) or measure the position in that point of the shaft. Program parameter *LRStI* with value 3 in the first digit on the right and exit programming.

Now press ENTER/RESET and *PrSt* will appear, press again 2 times ENTER/RESET and set the correct value to display, then confirm with ENTER/RESET. The display will now show the desired value.

If the required value is zero, instead of the preset function it is possible to use the reset function by setting 1 in the first digit on the right in the *LRStI* parameter so that pressing ENTER/RESET will bring the displayed value to zero.

Now that the instrument is adjusted, it is necessary to insert the desired *LRStI* parameter to avoid accidental reset/preset of the displayed value.

Battery replacement

The instrument is supplied with a ½AA 3,6V lithium battery, which assures a typical functioning of approximately 4 years.

When the battery runs down, an icon appears on the display.

The instrument is protected against inversion of polarity and wrong insertion, and in this case will not switch on.

Removing the battery from the instrument switches it off after a few seconds: at this point do not move the sensor to avoid losing the correct displayed value. As soon as the battery is fitted, the instrument switches on with the same value on the display which was present at the moment when it was switched off. If the sensor has not be moved, the displayed value will be correct. In case the sensor moved when the instrument was off, to re-establish the correct measure it is necessary to repeat the adjustment process.

Display icons

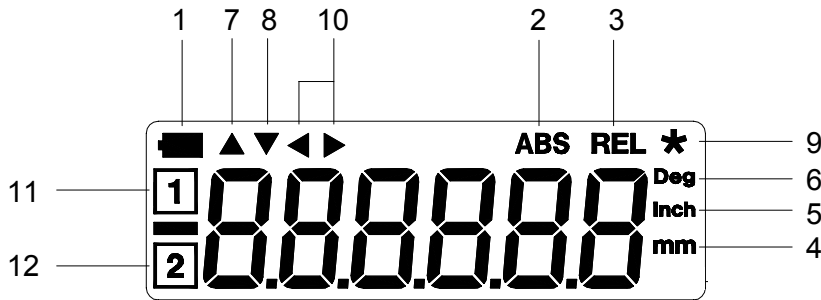

1. Indicator of flat battery: begins to blink when the level of loading goes under a certain value and when it keeps switched on its necessary to change the batteries within 1 month.
2. Indicator of absolute quota
3. Indicator of relative quota
4. Indicator of mm
5. Indicator of inches
6. Indicator of degrees
7. Indicator of positive Offset: indicates that the measure is corrected by a positive offset
8. Indicator of negative Offset: indicates that the measure is corrected by a negative offset
9. Indicator of values changing: it blinks during the programming phase
10. Indicator of origins: indicates that the origin changing mode is opened
11. Indicator for origin 1
12. Indicator for origin 2

Error message

oUEr: the current displayed value passed the maximum value that can be visualized (possible range: from -999999 to 999999).

Magnetic strip mounting

The magnetic strip P50 consists of a magnetized plastic ferrite strip with alternate magnetic poles of 5 mm pitch, carried by a ferromagnetic steel strip. Mechanical protection of the plastic ferrite strip is supplied by a non magnetic steel strip with thickness 0,2mm.

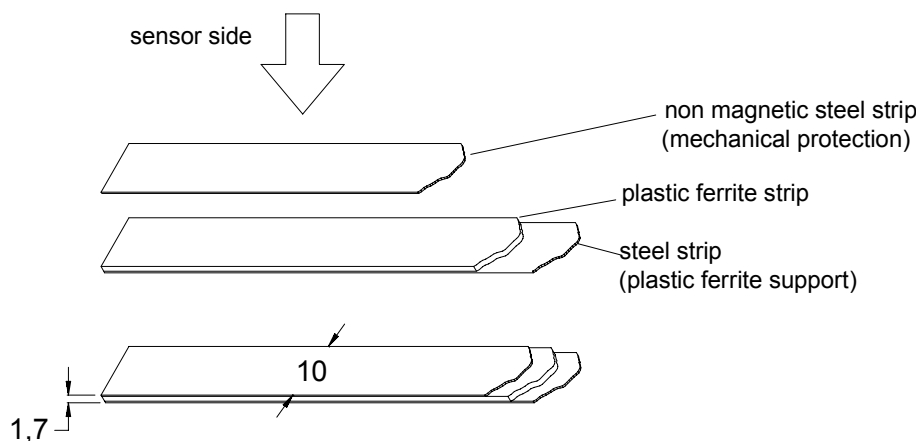

The magnetic strip is assembled by sticking it with a bi-adhesive tape. The surface has to be smooth, clean and dry: is advisable to clean it with a degreasing product (isopropyl alcohol, ethyl alcohol, solvents, etc). The magnetic strip has to be stuck holding the plastic ferrite side in the direction of the sensor, which means the steel side leaned on the stand surface. Fixed the magnetic strip, to keep off damages due to abrasions or grazes of the plastic ferrite strip, is advisable the appliance (always bi-adhesive) of the non magnetic protection strip. The optimal ambient temperature for stick the bi-adhesive tape is over 10°C. The maximum adherence of the tape works out after 48 hours (about) of the application and is kept between -10 and 80°C.

Sensor mounting

The sensor has been mounted according to the following drawing, and keeping the indicated tolerances. For the optimal system functioning it is necessary that the distance between the sensor and the magnetic band is not over 1mm of the useful stroke.

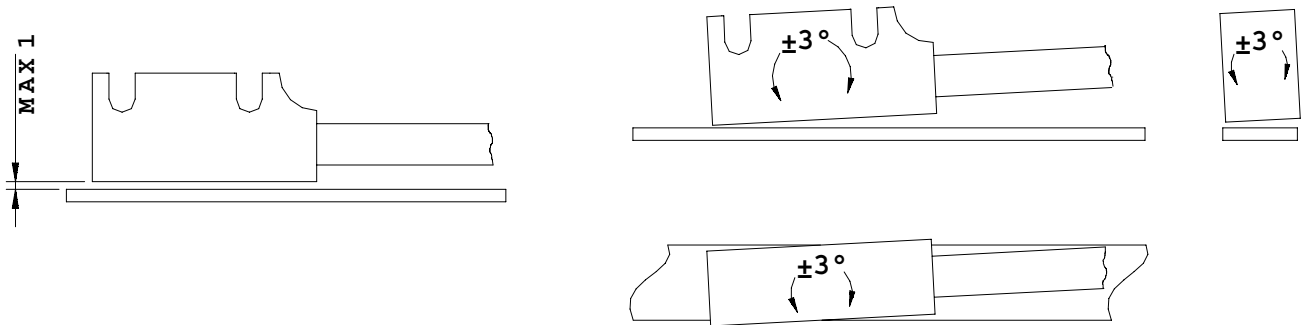

SENSOR

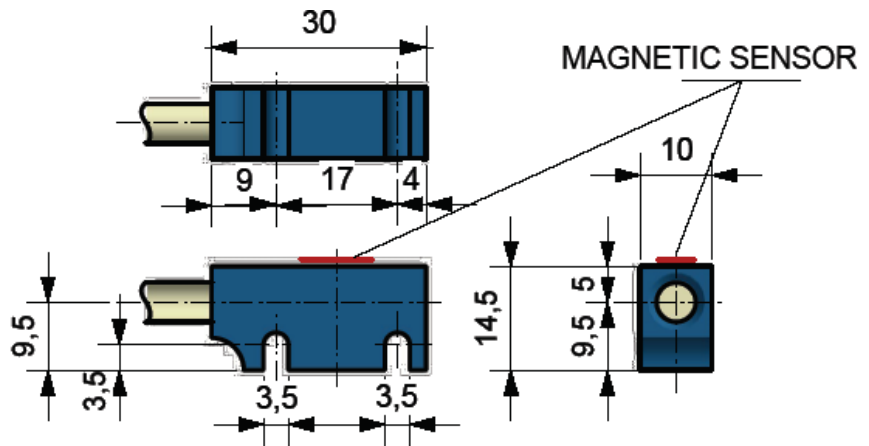

Mounting of magnetic ring (only for version F8P-E-AM)

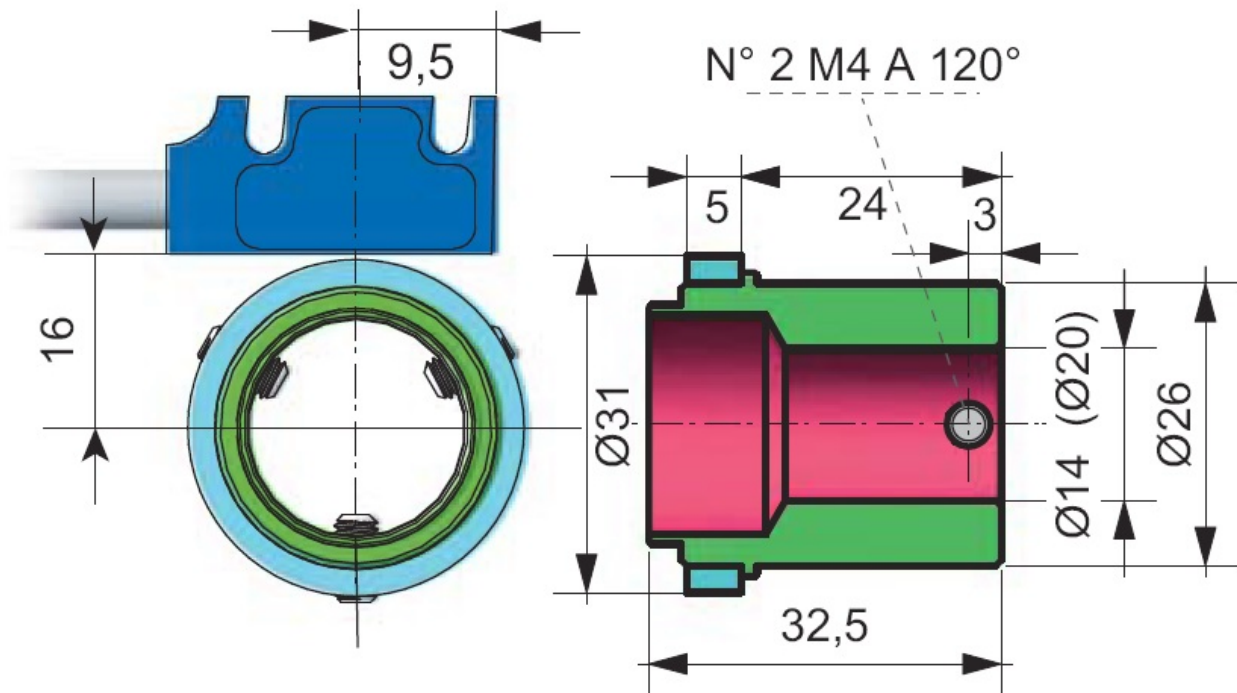

Technical features

Range display	-999999; 999999
Resolution	0,1mm
Max speed	2,5 m/s
Power supply	battery ½ AA, voltage 3,6V (lithium thionyl chloride)
Battery life	Typical 4 years continuous use
Display	High readability LCD with 10mm high digits
Keyboard	3 digits for programming and functions activation
Available functions	reset/preset, absolute/incremental value, mm/inch conversion, 3 distinct origins for tool changing
Protection degree	IP54 display, IP67 sensor
Sensor cable	length: 0,5 – 1 – 3 – 5 meters; Material: PUR Ø5,5mm suitable for movable wiring cable
Display and sensor house	aluminium black
Gap sensor – magnetic strip	1mm max
Working temperature	0-50°C
Relative humidity	35-85%
Electromagnetic compatibility	2014/30/EU
RoHS	2011/65/EU

Manufacturer

All communications to the manufacturer should be addressed to:

FIAMA s.r.l., Via G. Di Vittorio, 5/A - 43016 San Pancrazio (Parma) - Italy

Tel. (+39) 0521.672.341 - Fax. (+39) 0521.672.537 – e-mail: info@fiama.it - www.fiama.it

FIAMA srl is not responsible for any damage to persons or things caused by tampering and wrong use and in any case that are not consistent with the features of the instrument.

