



COMPANY WITH
QUALITY SYSTEM
CERTIFIED BY DNV GL
= ISO 9001:2015 =



USER'S MANUAL AND MAINTENANCE

ELECTRONIC DISPLAY FOR LINEAR MEASUREMENT

WITH SERIAL OUTPUT TYPE "SimplexE-RS"

Manual purpose

This manual has been designed by the Manufacturer to provide the necessary information regarding the instrument **SIMPLEX-E** to those who are authorized to carry out safely its installation, maintenance, dismantling and disposal.

All the necessary information for the buyers and planners can be found in the Sales catalogue. Other than adopting good technical construction methods, the information should be read carefully and strictly applied. Inobservance of this information could cause risks for the health and safety of people and economical damage. This information, provided by the Manufacturer in the original language(Italian) is also available in other languages to satisfy legislative and/or commercial needs. This manual must be kept in good conditions by a responsible person in an ideal place so that it is always available for consultation. In case this manual is lost or deteriorates, a replacement should be requested directly from the manufacturer quoting the manual's code. This manual reflects the state of skill of the instrument at the time of input on the market: however the manufacturer reserves the right to make changes, add or improve the manual without giving any reason to hold the present manual inadequate.

Identification of the equipment

The identification plate represented is applied on the instrument.

To find out the identification code of the instrument, consult the sales catalogue.

Environmental conditions

Temperature setting: min. 0°C, max. + 50°C.

It is forbidden to use the instrument other than its specific use and in potentially explosive conditions or where Anti-explosive elements are used.

Storage

Here below are some references to be followed for the storage of the instrument.

Avoid environments with excessive humidity and those exposed to bad weather (avoid open areas).

Avoid putting the instrument directly on the ground. Store the instrument in its original packing.

Conformity declaration and EC marking

The instrument answers to the following Communitarian Directives:

2014/30/EU Electromagnetic compatibility, 2011/65/EU RoHS.

Maintenance

The instrument does not needs a particular maintenance except cleaning to do only with a soft cloth dampen with ethylic alcohol or water. Do not use hydrocarbon solvents (petrol, diluents, etc.): the using of these products could affect the proper functioning of the instrument.

Reparations should be done only and exclusively at the FIAMA technical assistance centre.

Calibrations and tests

It is advisable to calibrate the instrument periodically, once every working year.

To do the calibration, follow the calibration procedure indicated in the present manual.

Assistance request procedure

For any kind of technical assistance request, contact the sales department of the Manufacturer directly indicating the information given on the identification plate, the number of hours used and the type of defect.

Manufacturer's responsibility

The manufacturer declines any responsibility in case of :

- Using the instrument contrary to the national safety and accident-prevention laws.
- Wrong installation, inobservance or wrong procedures of the instructions provided in the present manual.
- Defective electrical power supply.
- Modifications or tampering.
- Operations carried out by untrained or unqualified staff.

The safety of the instrument also depends on the strict observance of the procedures indicated in the manual: always operate the instrument in its functioning capacity and carry out a careful routine maintenance.

- All phases of inspection and maintenance should be done by qualified staff.
- The configurations provided in the manual are the only ones permitted.
- Do not try to use it anyway contrary to the indications provided.
- The instructions in this manual do not substitute but accomplish the obligations of the current legislation regarding the safety laws.

Installation

Before installing the instrument, read the following warnings:

- Connect the instrument strictly following the instructions of the manual.
- It is the responsibility of the user to check, before using, the correct settings of the parameters of the instrument to avoid damage to persons or things.
- The instrument CANNOT function in a dangerous environment (inflammable or explosive).
- The unit has sensible parts to electrostatic charge, therefore the handling of the inner electronic cards has to be carried out with appropriate care to avoid permanent damages.

Description

The Electronic Simplex is a dimension display for the measure of linear shifting that combines in the same case the magnetic position transducer, the display and the battery supply. The display-unit runs on an aluminium bar in which is seated a magnetic band.

The display-unit running on the bar measures the real shifting carried out, removing clearances and misalignments. The LCD-display has 6 digits plus sign (range from -999999 to 999999); the digit height is 10mm that allows a very good readability also by distances.

With 3 frontal keys is possible to adapt the value that has been showed for a given shifting and switch on the functions of reset/preset of quota, absolute/relative quota and conversion mm/Inch. There are also available 3 distinct origins for the correction of quota by using different tools and the offset function for the balancing of tool wear. The display can be rotated at 90° for a parallel or orthogonal view to the measure bar. The easy assembling, and the measure accuracy make the SIMPLEX-E suitable for a large number of applications within industry machinery (packaging, wood-, aluminium-, sheet-working, silk-screen printing, etc.). Available version with serial output RS485, with MODBUS-RTU protocol, and power supply 24Vdc and inner rechargeable battery (5 months functioning without power supply) for connection with remote units.ù

The power supply is 10-25VDC, and a back-up battery inside the instrument assures the maintenance and updating of quota even without external power supply for about 6 months (the quota is displayed, the keys answer to the programming and the set functions, etc.).

When there is power supply the battery is recharged.

When there isn't power supply the serial port communication is not operating and the instrument doesn't answers to the master.

Programming

To step into the parameter programming press key ▲ and on the display appears **PASS**, now press 2 times key RESET and appear 4 zeroes, the first on the right is blinking, with keys ▲ (digit increase) and ◀ (digit selection), set out password **0273** and confirm with RESET. In case of wrong set-out of password it goes out of the programming. The parameters that have to be set can be run with key ▲ and in order of appearance they are:

VISUAL	value to be displayed for every turn of the shaft,
ndEC	number of decimal digits,
dIrCO	count direction,
ntASt I	keys opening mode
oFFSEt	displacement of origin,
SEtUP	not used.
Addr	address device
bAUD-r	Baud rate serial port communication

To enter into the modification of the selected parameter press two times RESET (one time displays only the value) and with keys ▲ and ◀ set the wanted value to be confirmed with RESET.

To go out of the programming press ◀

Value to be displayed for every turn of the hollow shaft VISUAL

This parameter together with the following one allows to programme the value which has to be displayed for 100mm of displacement. Practically its necessary to set the value that has to display corresponding to a shifting of 100mm. Manufacture's value is VISUAL=100.0, which is the necessary value to read the shifting in millimetres.

The range allowed is from 0,00001 to 999999 with setting of decimal point position that is, after programming of the last digit on the left, pressing key ◀ will blink the decimal pinpoint and with key ▲ it can be moved to the wanted position. Confirm with RESET.

Number of decimal digits *ndEC*

It is the number of decimal digits to visualize on the display, range allowed from 0 to 5.

Count direction *dIrCO*

Set out the count direction of the display, range allowed 0 or 1.

Setting 0 the value on the display increases, turning the hollow shaft clockwise.

Setting 1 the value on the display decreases, turning the hollow shaft clockwise.

Keys opening mode *NRSE I*

This parameter programmes the functions linked to the keys.

The value to set is a number of three digits so each key corresponds to a digit; the digit on the right stands for setting of key RESET, the digit in the middle stands for key ▲ while the last digit on the left stand for key ◀.

The values allowed are the following:

VALUE	KEY ◀	KEY ▲	KEY RESET
0	Not open	Not open	Not open
1	Function ABS/REL	Conversion mm/inch	Reset
2	Not open	Display in degrees	Preset
3	Not open	Not open	Fast Preset
4	Not open	Not open	Change of origin 0,1,2

Reset: function of reset of quota, pressing on key RESET the quota is zero-set .

Preset: function of preset of quota, pressing on key RESET the quota on the display became the same of the one set in parameter Preset. The setting of Preset value appears immediately after parameter *NRSE I* (if chose value 2).

Fast Preset: the fast setting of the quota on the display, pressing on key RESET appears Preset and pressing still 2 times RESET is possible to set the value directly (use keys ▲ ◀ and confirm with RESET). This function is useful when the quote on the display has often be corrected.

Origin change (quota correction for tool change): with this function 3 different origins (0,1,2) are programmable and passes from an origin to the other wit key RESET. Activating the function of origin change on the display appear two small arrows and the indication of the selected origin happens with the switching on of the origin indicators (see paragraph meaning of symbols). After setting 4 in the first digit on the right of

NRSE I, will appear PrS0 and pressing 2 times RESET has to be set the value to be read in this position of shaft for origin 0, confirm with RESET. It will appear PrS1 which is the value to be read for origin 1 in the present position of shaft: set the correct value and confirm with RESET. It will appears PrS2 which is the value to be read for origin 2 in the present position of shaft: set the correct value and confirm with RESET. It means PrS0, PrS1, PrS2 are references for the calibration, in a certain position of the shaft, in three different origins.

Function ABS/REL: Enables the pass from absolute to relative value, pressing key ◀ zero-set temporary the value to allow a relative shifting. On the display switches on indicator REL to indicate that the current quote is relative to the zero-point just created. Pressing still key ◀ reappears the absolute value and on the display switches on the indicator ABS.

Conversion mm/inch: Pressing key ▲ converts the measure from millimetre to inches and back with indication of inch/mm on the display and a decimal number more then for millimetres. By choosing 5 decimals for millimetres the conversion in inches is not allowed.

Visualization in degrees: Pressing on key ▲ on the display appears Deg to indicate the visualization of measure in degrees.

Origin displacement *OFFSET*

This parameter is added or subtracted from the current quota to correct the value showed on the display, for example following wear or changing of tool. Setting a positive value on display appears the current quota added to this value.

Set zero to exclude the offset function (manufacturer's value).

The offset is not available if the function of tool-change is selected.

Address device *Addr.*

This is the identification address of the unit, it must be unique for every device connected to the bus network, admitted value from 1 to 247.

Baud rate serial port communication *BAUD-r*

VALUE	Baud rate
0	4800
1	9600
2	19200
3	38400

Adjusting of quota

After the assembling of instrument on the machine and setting of all parameters, to visualize on the display the correct measure it is necessary to carry out the reset or preset of quota. Position the transducer in point where is known exactly the correct measure to display (ex. check-stroke) or measure the quota in that point of the axis.

Programme parameter ***RESET I*** with value 3 in the first digit on the right and go out of the programming.

Now press RESET and it will appear Preset, press again 2 times RESET and set on the display the correct measure to visualize, confirm with RESET and on the display appears the correct measure.

If the adjusting quota is worth to zero instead of the preset is possible use reset, setting value 1 on the first digit on the right of ***RESET I***, this way pressing RESET the value on the display will be zeroed.

Now that the instrument is adjusted its necessary re-establish to the wanted value parameter ***RESET I*** to avoid accidental reset/preset of quota.

Rotation of display

The Simplex-E is supplied standard with mounting position A.

To modify assembling position to **A** in **B** or vice versa, screw off the 4 screws M3, turn the instrument to the required position and screw again.

A**B**

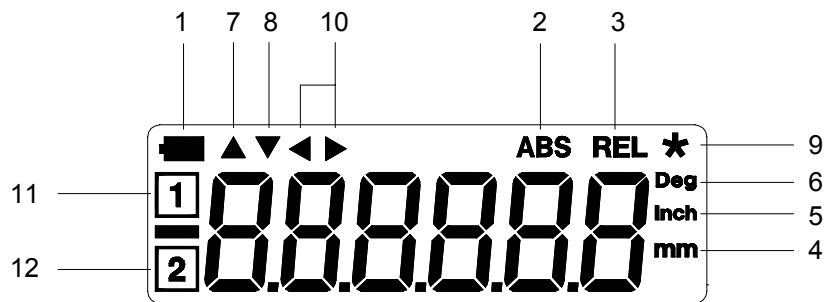
Meaning of the symbols on the display

1. Indicator of flat battery: begins to blink when the level of loading goes under a certain value and when it keeps switched on its necessary to change the batteries within 1 month.
2. Indicator of absolute quota
3. Indicator of relative quota
4. Indicator of mm
5. Indicator of inches
6. Indicator of degrees
7. Indicator of positive Offset: indicates that the measure is corrected by a positive offset
8. Indicator of negative Offset: indicates that the measure is corrected by a negative offset
9. Indicator of values changing: it blinks during the programming phase
10. Indicator of origins: indicates that the origin changing mode is opened
11. Indicator for origin 1
12. Indicator for origin 2

Erros messages

overfl: the current quota passed the maximum value that can be visualized (from -999999 to 999999);

error1: its necessary to adjust again the quota;

notape: inner failure, contact the technical assistance..

Protocol of serial port connection

The device has a serial output connection RS485 with MODBUS RTU protocol to dialogue with remote units. When there isn't power supply the serial port is not operating and the instrument doesn't answers to the master.

Below is a list of the registers of the instrument with the relative addresses and number of bytes. It is possible to read and write on these registers, using the query reading/writing ModBus compatible.

Parameter	Address ModBus (16 bit register)	Type (n° bytes)	Read Write
Dimension on display	0x00	Signed Long (4)	R
ndEC (position of decimal point)	0x02	Unsigned Char (1)	RW
U IS₀AL (correction factor)	0x03	Unsigned Long (4)	RW
U IS₀AL (number of decimal digit on U IS₀AL value)	0x05	Unsigned Char (1)	RW
Preset dimension value	0x06	Signed Long (4)	RW
Preset dimension value Preset1 (origin 1)	0x08	Signed Long (4)	RW
Preset dimension value Preset2 (origin 2)	0x0A	Signed Long (4)	RW
Preset dimension value Preset3 (origin 3)	0x0C	Signed Long (4)	RW
OFFSE value	0x0E	Signed Long (4)	RW
NEARSE 1 value	0x10	Unsigned Char (1)	RW
d IrCO_n count direction	0x11	Unsigned Char (1)	RW
Command register (see below)	0x12	Unsigned Char (1)	W
Status register (see below)	0x13	Unsigned Char (1)	R

Command register: writing a suitable control in this register is it possible to force the reset/preset, absolute/relative quota, origin change, etc. as in the following schedule (in order of increasing priority in case of more height bit at the same time):

0x01	→	Reset Dimension
0x02	→	Preset Dimension
0x04	→	Toggle absolute/relative ABS/REL dimension
0x08	→	Axe origin change
0x10	→	Current position stored as Preset for origin1
0x20	→	Current position stored as Preset for origin2
0x40	→	Current position stored as Preset for origin3
0x80	→	Conversion mm/inch

Status register: the reading of this register allows knowing the display mode of the device.

S_B7	S_B6	S_B5	S_B4	S_B3	S_B2	S_B1	S_B0
-	-	-	S_MI_4	S_MI_3	S_IA_2	S_IA_1	S_IA_0

S_IA_2 ... S_IA_0 status bits for absolute/relative dimension for use with and without origin according below table:

CURRENT STATE DISPLAY	S_IA_2	S_IA_1	S_IA_0
Absolute Quote (ABS)	0	0	0
Relative Quote (REL)	0	0	1
Origin0 ABS	0	1	0
Origin0 REL	0	1	1
Origin1 ABS	1	0	0
Origin1 REL	1	0	1
Origin2 ABS	1	1	0
Origin2 REL	1	1	1

S_MI_3, S_MI_4 bits for mm/inch conversion: S_MI_3=1 for display mm, S_MI_4=1 for display in inch.

The activated MODBUS commands are:

0x03: multiple reading of registers

0x10: writing of several registers.

0x03 READING OF REGISTERS

To read the registers of the instrument, the master must send a query composed as follows (every element is a byte):

ADDRESS | 0x03 | START_REG_HI | START_REG_LO | N_REG_HI | N_REG_LO | CRC_HI | CRC_LO

- START_REG_HI | START_REG_LO is the address at the starting 16 bit for the reading
- N_REG_HI | N_REG_LO is the number (16 bit) of the registers to be read

The instrument replies with the following message:

ADDRESS | 0x03 | NBYTE | DATA_1_HI | DATA_1_LO | DATA_2_HI | DATA_2_LO | ... | CRC_HI | CRC_LO

DATA_1_HI | DATA_1_LO | DATA_2_HI | DATA_2_LO | ... is the sequence of the data read..

NBYTE is the number of the given bytes that follow

DATA_1_HI | DATA_1_LO | DATA_2_HI | DATA_2_LO | ... is the stream of data read.

0x10 WRITING OF REGISTERS

To write the registers of the instrument, the master must send a query composed as follows (every element is a byte):

ADDRESS | 0x10 | START_REG_HI | START_REG_LO | N_REG_HI | N_REG_LO | NBYTE | DATA_1_HI | DATA_1_LO | DATA_2_HI | DATA_2_LO | | CRC_HI | CRC_LO

The instrument replies with the following message:

ADDRESS | 0x10 | START_REG_HI | START_REG_LO | N_REG_HI | N_REG_LO | CRC_HI | CRC_LO

Overall dimensions

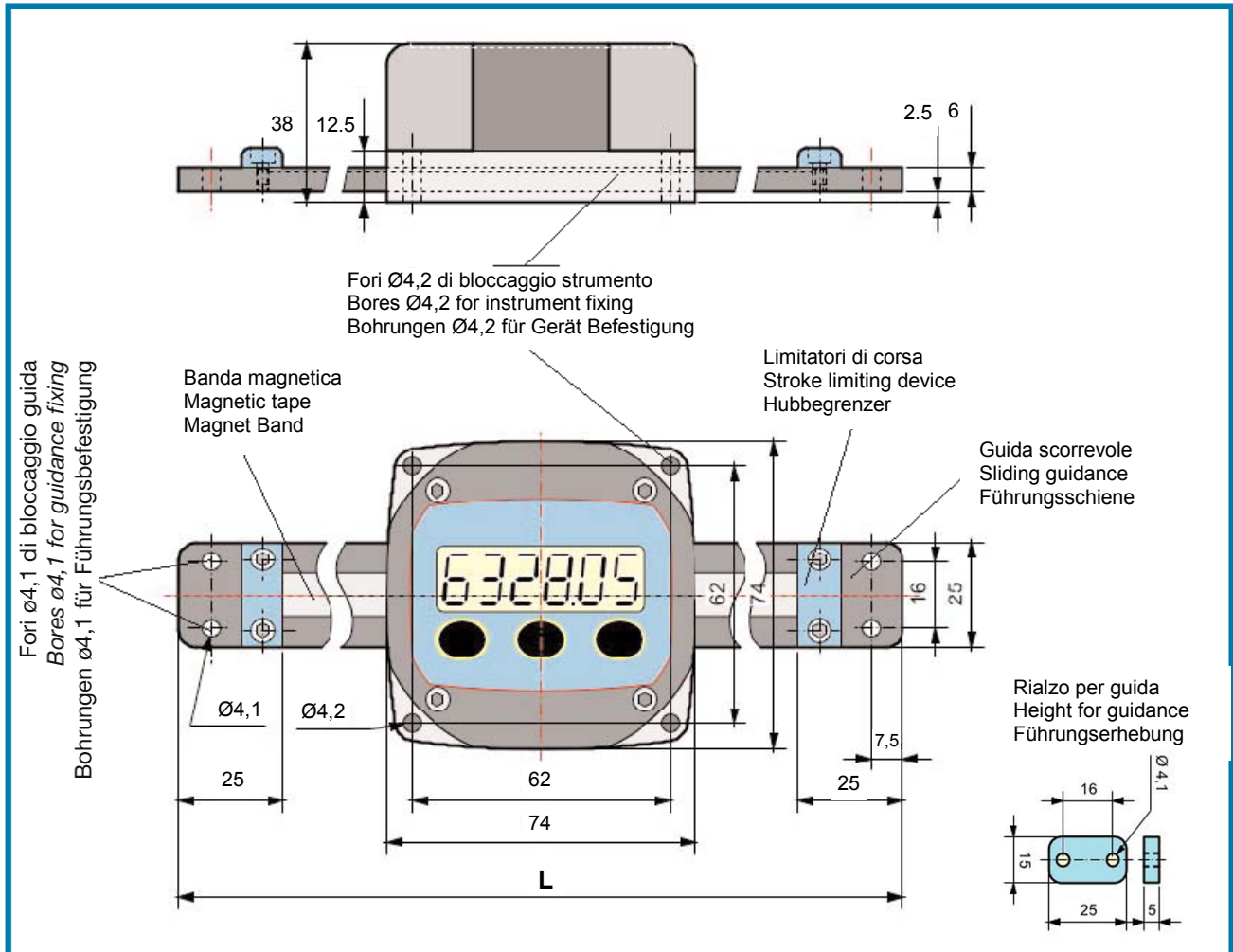

SIMPLEX - E	50	100	200	300	500	700
Mesaure	55	105	205	305	505	705
Display	55.00	105.00	205.00	305.00	505.00	705.00
Guidance length	t	180	230	330	430	630

Connection scheme



Male connector 4 pin M8

- 1 Brown +10-30Vdc
- 2 White serial Out RS485+
- 3 Blue GND
- 4 Black serial Out RS485-

PLEASE PAY ATTENTION: A WRONG ELECTRICAL CONNECTION COULD DAMAGE THE UNIT !!

Specifications

Power supply	10 - 25 Vdc max 100mA
Resolution	0,01 mm
Max speed	1,5 m/s
Reading range	-999999; 999999
Display	LCD high-visibility-digit
Serial port	RS485 protocol MODBUS RTU
Baud rate	4800, 9600, 19200, 38400 baud
Measure lengths	55, 105, 205, 305, 505, 705 mm
Keyboard	3 keys for programming and Offset
Available functions	Reset/preset, absolute/incremental quota , conversion mm/inches 3 distinct origin for tool change and balancing of tool wear.
Measure bar	Anodized aluminium
Box	Strengthen polyamide glass, oil-, fat-proof
Protection degree	IP54 - optional IP65
Working temperature	0-50°C
Relative humidity	30-90%
Directive: 2014/30/EU Electromagnetic compatibility, 2011/65/EU RoHS	

Manufacturer

All communications to the manufacturer should be addressed to:

FIAMA s.r.l., Via G. Di Vittorio, 5/A - 43016 San Pancrazio (Parma) - Italy

Tel. (+39) 0521.672.341 - Fax. (+39) 0521.672.537 – e-mail: info@fiama.it - www.fiama.it

FIAMA Srl is not responsible for any damage to persons or things caused by tampering and wrong use and in any case that are not consistent with the features of the instrument.

