



COMPANY WITH  
QUALITY SYSTEM  
CERTIFIED BY DNV GL  
= ISO 9001:2015 =



## USER MANUAL AND MAINTENANCE GUIDE DIGITAL ELECTRONIC INDICATORS WITH INDUSTRIAL FIELDBUS (Profinet, EthernetIP, Ethercat, IO-Link, Modbus)

EP43RS, EP46RS  
EP43NET, EP46NET  
F4RS-MT, F4RS-M12  
F4RS-AM, F4RS-EM43, F4RS-EM46  
F4NET-MT, F4NET-M12  
F4NET-AM, F4NET-EM43, F4NET-EM46

## 1 Manual purpose

This manual has been designed by the Manufacturer to provide the necessary information regarding the EP4 and F4 device series to those who are authorized to carry out safely its installation, maintenance, removal and disposal. All the necessary information for the buyers and planners can be found in the Sales documentation. In addition to adopting good technical construction practices, the information should be read carefully and strictly applied. Failure to observe this information could cause risks for the health and safety of people and economical damage. This information, provided by the Manufacturer in the original language (Italian) is also available in other languages to satisfy legislative and/or commercial needs. This manual must be kept in good conditions by a responsible person in an ideal place so that it is always available for consultation. In case this manual is lost or deteriorates, a replacement should be requested directly from the manufacturer indicating the manual's code. This manual reflects the state of the instrument at the time of input on the market: however, the manufacturer reserves the right to make changes, add or improve the manual without further notice.

### 1.1 Identification

The identification label is applied on the instrument.

To determine the identification code of the instrument, consult the sales documentation.

### 1.2 Environmental conditions

Temperature range: min. 0°C, max. + 50°C.

It is forbidden to use the instrument other than for its specific use and in potentially explosive conditions or where anti-explosive elements are required.

### 1.3 Storage

Here below are some references to be followed for the storage of the instrument:

Avoid environments with excessive humidity and those exposed to bad weather (avoid open areas).

Avoid putting the instrument directly on the ground.

Store the instrument in its original packaging.

### 1.4 Conformity declaration and EC marking

The instrument respects the following Communitarian Directives:

2014/30/EU Electromagnetic compatibility, 2011/65/EU RoHS.

### 1.5 Maintenance

The instrument does not need particular maintenance except cleaning, only with a soft cloth dampened with ethyl alcohol or water. Do not use hydrocarbon solvents (petrol, thinners, etc.): the use of these products could affect the proper function of the instrument.

Repairs should be done only and exclusively at the FIAMA technical assistance centre.

### 1.6 Calibrations and tests

It is advisable to calibrate the instrument periodically, once every working year.

To conduct calibration, follow the calibration procedure described in the present manual.

### 1.7 Technical Support

For any kind of technical assistance, contact the sales department of the Manufacturer directly indicating the information given on the identification label, the number of hours used and the type of defect.

### 1.8 Manufacturer's responsibility

The manufacturer declines any responsibility in case of:

- Using the instrument contrary to applicable national safety and accident-prevention laws.
- Incorrect installation, inobservance of, or incorrect procedures in contrast with the instructions provided in the present manual.
- Defective electrical power supply.
- Modifications or tampering.
- Operations carried out by untrained or unqualified staff.

The safety of the instrument also depends on the strict observance of the procedures indicated in the manual: always operate the instrument in its functioning capacity and carry out a careful routine maintenance.

- All phases of inspection and maintenance should be carried out by qualified staff.
- The configurations indicated in the manual are the only ones permitted.
- Do not attempt to use the instrument in anyway which is contrary to the indications provided.
- The instructions in this manual do not substitute but are a complement to the obligations of the current legislation regarding safety laws.

---

# Digital position indicators with fieldbus – user manual

## 2 Installation

Before installing the instrument, heed the following warnings:

- Connect the instrument strictly following the instructions of the manual.
- It is the responsibility of the user to check, before using, the correct setting of all parameters of the instrument to avoid damage to persons or things.
- The instrument CANNOT function in a hazardous environment (flammable or explosive).
- The unit contains parts sensitive to electrostatic charge, therefore handling of the internal electronic boards has to be carried out with appropriate care to avoid permanent damage.

## 3 Description

The instruments of the **F4** and **EP4** series are position indicator units with an integrated position sensor, providing a comprehensive system for measuring linear or rotary displacements.

The fieldbus output (available in Profinet, EthernetIP, Ethercat, IO-Link versions) allows connection to a PLC or remote supervision system, enabling the creation of a compact measurement device that is easy to install and applicable to various types of industrial machinery (such as packaging, woodworking, aluminum, sheet metal, etc.) for implementing manual format changes using handwheels operated by the operator.

The following versions are available:

- F4 with a linear magnetic tape type P50 position transducer,
- F4 AM with a rotary position transducer with magnetic ring mounting with pass-through hollow shaft with diameters 25mm (AM25), 20mm (AM20), 14mm (AM14),
- F4 EM43 with a rotary transducer with pass-through shaft diameter 14mm,
- F4 EM46 with a rotary transducer with pass-through shaft diameter 20mm or 25mm,
- EP43 with the position transducer with pass-through hollow shaft mounting of diameter 14mm integrated into the container,
- EP46 with the position transducer with pass-through hollow shaft mounting of diameter 20mm integrated into the container.

The backlit LCD display has 2 lines: the first indicates the current machine position to the operator, while the second shows the position to reach for the new machine configuration. This target position is communicated to the EP4 (or F4) via the fieldbus through the PLC, enabling manual format changes through handwheel operation. Two LED indicators, green and red, indicate whether the new positioning position has been reached or not.

With three buttons on the front panel, it is possible to program the value to be shown on the display for each turn of the hollow shaft and activate functions such as reset/preset of the position, absolute/relative position, mm/inch conversion (all of these functionalities are also accessible from the remote supervisor).

All activated functions are shown with symbols on the display.

The instrument must be externally powered with a voltage of 10-30VDC and has an internal backup battery that ensures the maintenance and updating of the position, even in the absence of external power, for a period of 6-8 years. In the absence of external power, the display is turned off, and communication on the bus is not managed.

The robust housing of EP4 and F4 is made of solid machined and anodized aluminum alloy, while the command hollow shaft is made of stainless steel and rotates on ball bearings.

## 4 Unit programming

### 4.1 User menu

Note: All the following parameters are also available on the fieldbus.

To access programming of the parameters, keep pressed until **PASS** appears on the display. Then press **O** 2 times and 3 zeroes will appear. The first digit on the right will blink: using **▲** (digit increase) and **◀** (digit selection) insert the pass code which is 273 and confirm with **O**. In case of incorrect insertion of the password, the unit exits the programming mode.

The various parameters can be scrolled with **▲** button and appear in the following order:

<b>u IS</b>	value to be shown after one complete rotation of the shaft
<b>ndEC</b>	number of decimal places
<b>tASt</b>	button activation mode
<b>PrSO</b>	preset quote
<b>d lr</b>	count direction
<b>LoOP</b>	backlash compensation value
<b>tGt</b>	target value
<b>InPoS</b>	tolerance around target value
<b>Addr</b>	device address
<b>bAUd</b>	serial port communication baud rate
<b>PAr</b>	parity bit

To modify the selected parameter press **O**. The value can be changed with **▲** and **◀** buttons. Confirm with button **O**.

To exit programming press **◀**.

#### 4.1.1 Firmware revision

In the password menu of the keypad, by entering the password 732, it will be possible to view information regarding the version of the instrument and its firmware release.

Note: all versions are compatible with each other.

## 4.2 Configuration parameters

### 4.2.1 Value to be shown after one complete rotation of the hollow shaft: Vis

This parameter, together with the following one, defines the value which is shown after one rotation of the hollow shaft. The allowable range is from 0,0001 to 99999. The decimal place is set after programming the last digit on the left: after pressing, the decimal place will blink and with it can be moved to the desired position. Confirm with **O**.

In the version with a linear transducer for linear magnetic tape (F4), this parameter corresponds to the value shown on the screen for a displacement of 40mm. With the default value of 40.0, the display shows the measurement in millimeters and tenths.

In the version with a rotary transducer, this parameter corresponds to the value to be shown on the screen for each revolution of the hollow shaft.

### 4.2.2 Number of decimal places nDec

It is the number of decimal places to visualize on the display, allowed range from 0 to 4.

Example 1: if each rotation of the hollow shaft will cause a displacement of 50, set **u IS**=50 and **ndEC**=0.

Example 2: if each rotation of the hollow shaft will cause a displacement of 12,345 and the desired output on the display is 12.3, set **u IS**=12.345 and **ndEC**=1.

### 4.2.3 Button activation mode: nTasti

This parameter programs the button functions.

The value is a number with 3 digits, each corresponding to a button: the digit on the right sets the **O** button, the digit in the middle sets while the last digit on the left sets.

The possible values are in the following table:

## Digital position indicators with fieldbus – user manual

VALORE	TASTO ◀	TASTO ○	TASTO ▲
0	Not active	Not active	Not active
1	mm/inch conversion	Reset	ABS/REL measurement
2	Not active	Preset	Not active
3	Not active	Fast Preset	Not active
4	Not active	Delayed Reset after 3s (*)	Not active
5	Not active	Delayed Preset after 3s (*)	Not active

(\*) Delayed means that to activate the function (reset or preset), it is necessary to keep ○ pressed for approximately 3 s.

**1) Reset:** reset function of the shown value; after pressing ○ the shown value is set to zero.

**2) Preset:** preset function of the shown value; after pressing ○ the shown value becomes equal to the value in the **Pr5t0** parameter, which can be set immediately after **Er5t1** (when the digit on the right is set to 2). *Preset* function is disabled when *loop* parameter is not zero.

**3) Fast Preset:** the fast setting of the shown value on the display; after pressing ○, **Pr5t0** appears and pressing 2 times ○ it is possible to set the value directly (use and then confirm with ○). This function is useful when the shown value must be corrected often. *Preset* function is disabled when *loop* parameter is not zero.

**4) Delayed Reset:** to activate the function reset it is necessary to keep ○ pressed for approximately 3 s

**5) Delayed Preset:** to activate the function preset it is necessary to keep ○ pressed for approximately 3 s

**6) ABS/REL measurement:** Enables switching from an absolute to relative value; after pressing ◀, the shown value is temporarily set to zero to measure a relative motion of the shaft. On the display the rel icon indicates that the current display is relative to the reference point that has just been created. Pressing again causes the absolute value to be shown and the abs icon will appear.

Note: The ABS/REL function is enabled only if the measurement is in mm units.

**7) mm/inch conversion:** Pressing converts the measurement from millimeters to inches and back. When in inch mode, the inch icon will appear and the shown value will have an additional decimal place. When the parameter *ndEE*=4 the mm/inch conversion is not available.

### 4.2.4 Count direction: dir

It sets the count direction, allowed values are 0 or 1.

By setting 0, the shown value increases turning the shaft clockwise.

By setting 1, the shown value decreases turning the hollow shaft clockwise.

### 4.2.5 Target Value: tgt

Value shown on the first line of the display which indicates the position which must be reached by manual adjustment.

### 4.2.6 Backlash compensation value: Loop

If set different to zero, at each inversion of the rotation direction, the shown value does not change until the shaft completes a rotation which is equal to or above the backlash compensation value.

Set a positive value for backlash compensation in the forward direction and a negative value for compensation in the reverse direction. *Preset* function is disabled when *loop* parameter is not zero.

### 4.2.7 Tolerance around target value: InPos

When the actual value reaches inside the window around the target value (which is defined by the tolerance) the red LED is turned off the green LED is turned on.

Example: with target value **Er5t**=50 and **InPos**=10, the green LED is on between 40,1 e 59,9.

### 4.2.8 Device address: Addr

#### 4.2.8.1 Ethercat version

Default value: 0.

This parameter allows setting the address for Ethercat communication. Use this function ONLY if you are not using the automatic addressing available with the Ethercat protocol.

---

# Digital position indicators with fieldbus – user manual

Allowed values:

- 0 [uses automatic addressing]
- [1-255]

## 4.2.8.2 Modbus version

This constant represents the address of the instrument for MODBUS communication with the MASTER unit. Possible values range from 1 to 247. Default value: 1.

## 4.2.8.3 other versions

Unused in IO-Link, profinet e EthernetIP versions.

## 4.2.9 Baud rate serial communication: Baud

This parameter is only present in the version with RS485 Modbus serial output and is used to set the baudrate of the serial communication:

VALORE	Baud rate
0	9600
1	19200
2	38400
3	57600
4	115200

## 4.2.10 Parity bit: Par

This parameter is only present in the version with RS485 Modbus serial output and is used to set the parity bit of the serial communication:

VALORE	Parità
0	even
1	odd
2	no parity 2 stop bit

## 4.3 Status LEDs

The two LEDs positioned beside the display light up according to the current position value, the target position value, and the InPos parameter value.

If the current position is within the range [target position - InPos; target position + InPos], the green LED will light up. Otherwise, the red LED will light up.

## 4.4 Position calibration (via keypad)

After mounting the instrument on the machine and setting all the parameters, to show the correct measurement on the screen, it is necessary to perform the reset or preset of the position. Position the machine at a point where the correct measurement to be shown is known precisely (e.g., reference stop) or measure the position at that point on the axis. Program the parameter **nrPSE** with the value 3 in the middle digit and exit programming. Now press the **O** button, and the word "Preset" will appear. Press **O** and set the correct measurement to be shown on the screen, confirm with **O**, and the correct measurement will appear on the display. If the calibration position were to be zero, instead of the preset, it is possible to use the reset by setting the value 1 in the middle digit of the **nrPSE** parameter. Then, pressing **O** will zero the measurement on the display.

Now that the instrument is calibrated, it is necessary to restore the **nrPSE** parameter to the desired value to avoid accidental reset/preset of the position.

## 5 Battery

The battery status is indicated by the icon on the display and is reported in the specific registers of the fieldbus.

Note: the battery status indicators (icon on display and value on the bus) are updated when the instrument is powered exclusively by the battery, without external power supply.

### 5.1 Battery replacement

The battery ensures the maintenance and updating of the position in the absence of external power for at least 6-8 years depending on usage conditions (there is no battery consumption when the instrument is powered). When the battery icon appears on the display or under the previously indicated conditions, the battery replacement must be carried out within 15 days.

The replacement procedure is as follows:

1. Power the instrument with external power (to prevent the loss of machine position). If it is necessary to remove the 24V power supply, proceed with recalibrating the position afterward.
2. Unscrew the two hex screws and remove the battery cover (note: the cover is connected to a flexible cable and requires maximum attention not to damage or bend it at sharp angles).
3. Remove the depleted battery.
4. Insert the new battery type ½ AA 3.6V, respecting the polarity (negative pole inward).
5. Close the cover, ensuring that the cable is correctly inserted along the length of the battery.

## 6 Communication protocols

In the following paragraphs, the operation mode of the EP4 and F4 units is described in all available versions (Modbus, Profinet, EthernetIP, Ethercat, IO-Link).

Please refer ONLY to the version in use.

---

# Digital position indicators with fieldbus – user manual

## 6.1 Modbus

The EP4 and F4 series instruments are equipped with serial communication, following the Modbus RTU standard, on an RS485 line. When a power supply is not available, the serial port is not active and the instrument does not respond to the master.

The data format exchanged consists of 8-bit words with 1 stop bit and a parity bit according to what is set in the programming parameter Par. The protocol is based on a QUERY/RESPONSE structure: slave devices respond to queries from a master with a message containing the identifying address and the requested data. The MODBUS protocol ensures the validity of the exchanged data over the line with a "Cyclic Redundancy Check" error control; two CRC bytes are appended to the messages.

Further Information on the creation of two CRC bytes are available on [www.modicon.com](http://www.modicon.com).

The activated MODBUS commands are:

0x03: multiple reading of registers

0x10: writing of several registers.

0x06 writing of one register.

### 6.1.1 Reading registers

To read the registers of the device, the network master must send a query composed as follows (every element is a single byte):

ADDRESS | 0x03 | START\_REG\_HI | START\_REG\_LO | N\_REG\_HI | N\_REG\_LO | CRC\_HI | CRC\_LO

START\_REG\_HI | START\_REG\_LO is the address at the starting 16 bit for the reading

N\_REG\_HI | N\_REG\_LO is the number (16 bit) of the registers to be read

The device replies with the following message:

ADDRESS | 0x03 | NBYTE | DATA\_1\_HI | DATA\_1\_LO | DATA\_2\_HI | DATA\_2\_LO | ... | CRC\_HI | CRC\_LO

NBYTE is the sequence of the data read

DATA\_1\_HI | DATA\_1\_LO | DATA\_2\_HI | DATA\_2\_LO | ... is the stream of data read.

### 6.1.2 Register writing

To write the registers of the device, the network master must send a query composed as follows (every element is a single byte):

ADDRESS | 0x10 | START\_REG\_HI | START\_REG\_LO | N\_REG\_HI | N\_REG\_LO | NBYTE | DATA\_1\_HI | DATA\_1\_LO | DATA\_2\_HI | DATA\_2\_LO | ... | CRC\_HI | CRC\_LO

The device replies with the following message:

ADDRESS | 0x10 | START\_REG\_HI | START\_REG\_LO | N\_REG\_HI | N\_REG\_LO | CRC\_HI | CRC\_LO

#### Note:

In case the writing of registers is implemented with a sequence of single writes (i.e., a query to write the first register, followed by a second query to write the second register, and so on), it is MANDATORY to insert a delay of at least 100ms (milliseconds) between writing register 0 (Vis) and writing register 2 (vDec).



# Digital position indicators with fieldbus – user manual

## 6.1.3 Parameters

The parameters that can be read/written through serial communication are listed in the table below. A more detailed explanation of the following parameters is available in the "User Menu" chapter.

Indirizzo modbus	Parametro	Size	Range	Default value	Funzione
0	Visual	4	1..99999	<ul style="list-style-type: none"> <li>1000 (EP4)</li> <li>400 (F4)</li> </ul>	<ul style="list-style-type: none"> <li>value to be shown after one complete rotation of the shaft (EP4)</li> <li>value to be shown after 40mm displacement (F4)</li> </ul>
2	vDec	2	0..4	1	It is the number of decimal places in the Visual parameter
3	nDec	2	0..4	1	It is the number of decimal places to visualize on the display
4	nTasti	2	0..0x151	0x111	It is the button activation mode
5	Dir	2	0..1	0	Counting direction
6	Preset	4	-99999 +99999	0	Preset position value
8	Loop	4	-99999 +99999	0	Backlash compensation value
10	Positioning window	2	0..30000	10	Positioning window value
11	Error	2			Refer to the next section "battery status"
12	Quota	4	-99999 +99999		
14	Target	4	-99999 +99999		
16	Control	2			<p>By writing the indicated values via Modbus, it is possible to activate the corresponding functionalities:</p> <p>0x4141: Activates the always-on display feature.</p> <p>0x4040: Deactivates the always-on display feature.</p>

### 6.1.3.1 Always on display

By writing (via Modbus) 0x4141 to the Control register, the EP4 activates the "always-on display" functionality. The device will display the target position and the current position even in the absence of external power. Additionally, the configuration menu and the three buttons remain active. However, the status LEDs and the display backlight are turned off. The impact on battery consumption of this functionality is approximately 15%.

By writing 0x4040 to the Control register, the EP4 deactivates the "always-on display" functionality.

By writing 0x1111 to the Control register, the EP4 resets the Error register to the value 0.

---

## Digital position indicators with fieldbus – user manual

### 6.1.3.2 Battery status

The battery status is indicated by the icon on the display and the Modbus Error register.

The Modbus *Error* register can take the following values to indicate the battery status:

- 0x0000: In case of optimal operating condition.
- 0xFFFF: If the battery level has dropped below a critical threshold. In this case, it is necessary to proceed with replacement within 15 days.
- 0x00FF: If the battery is completely discharged, absent, or faulty. In this case, the battery must be immediately replaced because in this state, it is not guaranteed that the instrument can save the current position value when the 24V power supply is removed.

**WARNING:** If this value is present in the Error register at machine startup, it is necessary to perform the machine repositioning procedure (homing or reset) because the position detected by the EP4 is no longer aligned with the actual position of the machine.

# Digital position indicators with fieldbus – user manual

## 6.2 Profinet

EP4 and F4 implement the Profinet IRT protocol (conformity class C) for IO-Device units, Ethernet interface. Communication consists of a cyclic part (*Status e Target*) and an acyclic part (*Parameters*).

To correctly associate EP4 and F4 devices with the appropriate Profinet ProductFamily, please refer to the table below:

Codice	Profinet device name	Profinet device id
EP43NET	EP4NET	0x0111
EP46NET	EP4NET	0x0111
F4NET-AM	EP4NET	0x0111
F4NET-MT	F4NET	0x0112
F4NET-M12	F4NET	0x0112
F4NET-EM43	EP4NET	0x0111
F4NET-EM46	EP4NET	0x0111

Please ensure to select the appropriate Profinet ProductFamily corresponding to your EP4 or F4 device model.

The communication (I/O) part of the two product families is identical.

The communication is structured into a cyclic part (*State and Target*) and an acyclic part (*Parameters*).

### 6.2.1 Cyclic communication (Process Data)

The cyclic communication of the EP4/F4 families is designed for the exchange of 10 input bytes and 4 output bytes. A punctual description of each byte is provided later on to make their understanding easier.

#### 6.2.1.1 Inputs (Slave → Master): 10byte, 5 word

Nome	Size (byte)	Tipo	Funzione
Status word	2	UINT	Word showing the device status (Status word table).
Actual position	4	DINT	Actual position
Actual target position	4	DINT	Target position which is currently shown on the display

**Status word:** when moving from 0 to 1, each bit in this word warns about a different status of the device. The meaning of each status is explained below.

## Digital position indicators with fieldbus – user manual

Bit	Nome	Descrizione
0	Ready	Device ready
1	Target reached	The current position is within the positioning window.
2	Battery low	The battery charge level is below a critical threshold: in this case it is necessary to substitute it within 15 days.
3	Battery fault	The battery is completely discharged, absent, or malfunctioning. In this case the battery must be immediately replaced because in this state it is not guaranteed that the instrument will be able to maintain the correct value when the 24VDC power supply is off. <b><u>NOTE: if this bit is present when the machine is turned on, it is necessary to execute a homing or reset procedure because the value measured by the EP4NET is no longer consistent with the actual position of the machine.</u></b>
4	Encoder fault	Internal encoder fault

### 6.2.1.2 Outputs (Master → Slave): 4 byte, 1 dword

Nome	Size (byte)	Tipo	Funzione
Target position	4	DINT	Target position to be shown on the display

# Digital position indicators with fieldbus – user manual

## 6.2.2 Acyclic communication (*record data*)

The EP4 and F4 device uses two groups of acyclic parameters which contain the 11 parameters used for configuration.

The first group contains the configuration parameters for visualization (the same parameters which are accessible from the device menu). These parameters are mapped as initial record data, that is as acyclic parameters whose value is written by the PLC at every new connection of the unit (and so also when the unit is powered on). These (initial) values are contained within the GSDML file and can be modified by the development environment of the control unit which is used.

Since they are acyclic parameters, they can be read and written, with the specific commands, also during operation; note that each time the unit is turned on, the PLC will restore the initial configuration.

All of these parameters can be read and written.

The second group contains only the current position and the target position in order to allow both a preset and acyclic reset. These two parameters are NOT mapped as initial record data. It is possible to conduct an acyclic write using a web server which is available at the IP address of the device, or through a function block.

All of the parameters can be modified in any moment.

### 6.2.2.1 Parameters

**Index: 3**

This set of parameters is used as **Initial Record Data**, i.e. as the initial values that the PLC automatically sends to the EP4\_NET unit whenever it is switched on.

For a more detailed description of the following parameters please refer to the *Unit programming* section.

Indice parametro	Parametro	Tipo	Range	Default value	Funzione
0	Visual	UDINT	1..99999	<ul style="list-style-type: none"><li>1000 (EP4)</li><li>400 (F4)</li></ul>	<ul style="list-style-type: none"><li>value to be shown after one complete rotation of the shaft (EP4)</li><li>value to be shown after 40mm displacement (F4)</li></ul>
1	vDec	UINT	0..4	1	It is the number of decimal places in the Visual parameter
2	nDec	UINT	0..4	1	It is the number of decimal places to visualize on the display
3	nTasti	UINT	0..0x151	0x111	Button activation mode
4	Dir	UINT	0..1	0	count direction
5	Preset	DINT	-99999 +99999	0	Preset value
6	Loop	DINT	-99999 +99999	0	backlash compensation value
7	Positioning window	UINT	0..30000	10	target value tolerance

### 6.2.2.2 Position

**Index: 4**

This set contains exclusively the two useful positions of the device.

It is possible to reset the positions or preset them to a desired value by using acyclic access.

Indice parametro	Parametro	Tipo	Range	Accesso	Funzione
0	Position	DINT	-99999 +99999	R/W	Actual position of device
1	Target position	DINT	-99999 +99999	R/W	Target position of device

# Digital position indicators with fieldbus – user manual

## 6.3 Ethernet IP communication protocol

EP4 and F4 implement the EthernetIP protocol for IO-Device units, Ethernet interface. Communication consists of a cyclic part (*Status e Target*) and an acyclic part (*Parameters*).

To correctly associate EP4 and F4 devices with the appropriate EthernetIP ProductFamily, please refer to the table below:

Codice	Ethernet IP prodName	EthernetIP prodCode
EP43NET	Fiama EP4NET	0x0111
EP46NET	Fiama EP4NET	0x0111
F4NET-AM	Fiama EP4NET	0x0111
F4NET-MT	Fiama F4NET	0x0112
F4NET-M12	Fiama F4NET	0x0112
F4NET-EM43	Fiama EP4NET	0x0111
F4NET-EM46	Fiama EP4NET	0x0111

Please ensure to select the appropriate Profinet ProductFamily corresponding to your EP4 or F4 device model.

The communication (I/O) part of the two product families is identical.

The communication is structured into a cyclic part (*State and Target*) and an acyclic part (*Parameters*)

### 6.3.1 Cyclic communication (Process Data)

The cyclic communication of the EP4/F4 families is designed for the exchange of 10 input bytes and 4 output bytes. A punctual description of each byte is provided later on to make their understanding easier.

#### 6.3.1.1 Inputs (Slave → Master): 10byte, 5 word

Nome	Size (byte)	Tipo	Funzione
Status word	2	UINT	Word showing the device status (Status word table).
Actual position	4	DINT	Actual position
Actual target position	4	DINT	Target position which is currently shown on the display

## Digital position indicators with fieldbus – user manual

**Status word:** when moving from 0 to 1, each bit in this word warns about a different status of the device. The meaning of each status is explained below.

Bit	Nome	Descrizione
0	Ready	Device ready
1	Target reached	The current position is within the positioning window.
2	Battery low	The battery charge level is below a critical threshold: in this case it is necessary to substitute it within 15 days.
3	Battery fault	The battery is completely discharged, absent, or malfunctioning. In this case the battery must be immediately replaced because in this state it is not guaranteed that the instrument will be able to maintain the correct value when the 24VDC power supply is off. <b><u>NOTE: if this bit is present when the machine is turned on, it is necessary to execute a homing or reset procedure because the value measured by the EP4NET is no longer consistent with the actual position of the machine.</u></b>
4	Encoder fault	Internal encoder fault

### 6.3.1.2 Outputs (Master → Slave): 4 byte, 1 dword

Nome	Size (byte)	Tipo	Funzione
Target position	4	DINT	Target position to be shown on the display

## Digital position indicators with fieldbus – user manual

### 6.3.2 Acyclic communication (*record data*)

The EP4 and F4 device uses two groups of acyclic parameters which contain the 11 parameters used for configuration.

The first group contains the configuration parameters for visualization (the same parameters which are accessible from the device menu). These parameters are mapped as initial record data, that is as acyclic parameters whose value is written by the PLC at every new connection of the unit (and so also when the unit is powered on). These (initial) values are contained within the GSDML file and can be modified by the development environment of the control unit which is used.

Since they are acyclic parameters, they can be read and written, with the specific commands, also during operation; note that each time the unit is turned on, the PLC will restore the initial configuration.

All of these parameters can be read and written.

The second group contains only the current position and the target position in order to allow both a preset and acyclic reset. These two parameters are NOT mapped as initial record data. It is possible to conduct an acyclic write using a web server which is available at the IP address of the device, or through a function block.

All of the parameters can be modified in any moment.

#### 6.3.2.1 Parameters

**Index: 3**

This set of parameters is used as **Initial Record Data**, i.e. as the initial values that the PLC automatically sends to the EP4\_NET unit whenever it is switched on.

For a more detailed description of the following parameters please refer to the *Programming* section.

Indice parametro	Parametro	Tipo	Range	Default value	Funzione
0	Visual	UDINT	1..99999	<ul style="list-style-type: none"> <li>1000 (EP4)</li> <li>400 (F4)</li> </ul>	<ul style="list-style-type: none"> <li>value to be shown after one complete rotation of the shaft (EP4)</li> <li>value to be shown after 40mm displacement (F4)</li> </ul>
1	vDec	UINT	0..4	1	decimal point position for <b>u 15</b>
2	nDec	UINT	0..4	1	decimal point position on display
3	nTasti	UINT	0..0x151	0x111	button activation mode
4	Dir	UINT	0..1	0	count direction
5	Preset	DINT	-99999 +99999	0	Preset value
6	Loop	DINT	-99999 +99999	0	backlash compensation value
7	Positioning window	UINT	0..30000	10	target value tolerance

#### 6.3.2.2 Position

**Index: 4**

This set contains exclusively the two useful positions of the device.

It is possible to reset the positions or preset them to a desired value by using acyclic access.

Indice parametro	Parametro	Tipo	Range	Accesso	Funzione
0	Position	DINT	-99999 +99999	R/W	Actual position of device
1	Target position	DINT	-99999 +99999	R/W	Target position of device



## Digital position indicators with fieldbus – user manual

To access the previous data structures acyclically, it is necessary to set the msg functions as follows (the example image is taken from the function available for rslgix5000):

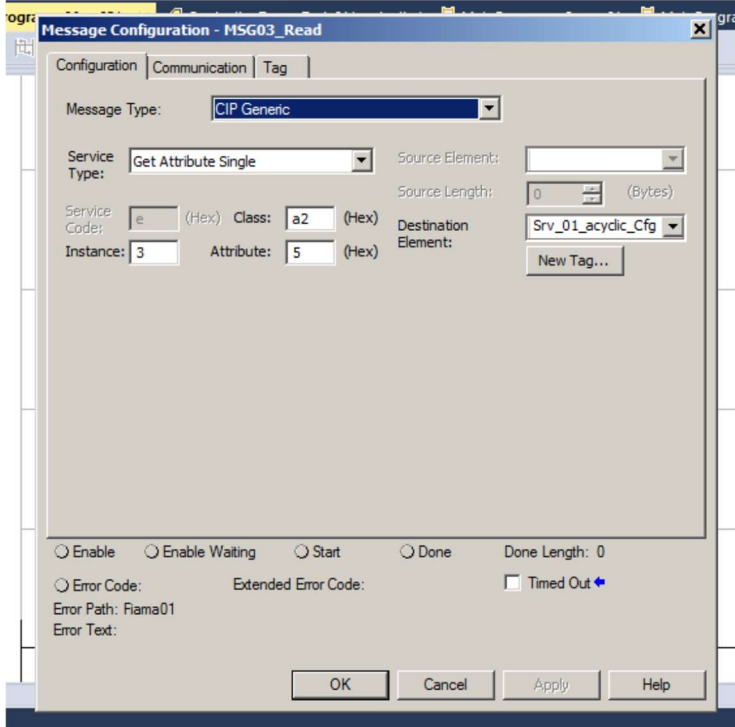

With this command, the entire parameter block is read from the PLC and saved in the structure set as the 'Destination element'. Similarly, for writing, the 'Set attribute single' command should be used to send a structure containing all the configuration bytes to the unit.

# Digital position indicators with fieldbus – user manual

## 6.4 Ethercat communication protocol

EP4 and F4 implement the Profinet IRT protocol (conformity class C) for IO-Device units, Ethernet interface. Communication consists of a cyclic part (Status e Target) and an acyclic part (Parameters).

The communication (I/O) part of the two product families is identical.

### 6.4.1 Cyclic communication (Process Data)

The cyclic communication of the EP4/F4 families is designed for the exchange of 10 input bytes and 4 output bytes. A punctual description of each byte is provided later on to make their understanding easier.

#### 6.4.1.1 Inputs (Slave → Master): 10byte, 5 word

Nome	Size (byte)	Tipo	Funzione
Status word	2	UINT	Word showing the device status (Status word table).
Actual position	4	DINT	Actual position
Actual target position	4	DINT	Target position which is currently shown on the display

**Status word:** when moving from 0 to 1, each bit in this word warns about a different status of the device. The meaning of each status is explained below.

Bit	Nome	Descrizione
0	Ready	Device ready
1	Target reached	The current position is within the positioning window.
2	Battery low	The battery charge level is below a critical threshold: in this case it is necessary to substitute it within 15 days.
3	Battery fault	The battery is completely discharged, absent, or malfunctioning. In this case the battery must be immediately replaced because in this state it is not guaranteed that the instrument will be able to maintain the correct value when the 24VDC power supply is off. <b><u>NOTE: if this bit is present when the machine is turned on, it is necessary to execute a homing or reset procedure because the value measured by the EP4NET is no longer consistent with the actual position of the machine.</u></b>
4	Encoder fault	Internal encoder fault

#### 6.4.1.2 Outputs (Master → Slave): 4 byte, 1 dword

Nome	Size (byte)	Tipo	Funzione
Target position	4	DINT	Target position to be shown on the display

# Digital position indicators with fieldbus – user manual

## 6.4.2 Acyclic communication (SDO)

The EP4 and F4 device uses two groups of acyclic parameters which contain the 11 parameters used for configuration.

The first group contains the configuration parameters for visualization (the same parameters which are accessible from the device menu).

The second group contains only the current position and the target position in order to allow both a preset and acyclic reset. It is possible to conduct an acyclic write using a web server which is available at the IP address of the device, or through a function block.

All of the parameters can be modified in any moment.

### 6.4.2.1 Parameters

#### Index: 3

This set of parameters is used as **Initial Record Data**, i.e. as the initial values that the PLC automatically sends to the EP4\_NET unit whenever it is switched on.

For a more detailed description of the following parameters please refer to the *Programming* section.

Indice parametro	Parametro	Tipo	Range	Default value	Funzione
0	Visual	UDINT	1..99999	<ul style="list-style-type: none"><li>1000 (EP4)</li><li>400 (F4)</li></ul>	<ul style="list-style-type: none"><li>value to be shown after one complete rotation of the shaft (EP4)</li><li>value to be shown after 40mm displacement (F4)</li></ul>
1	vDec	UINT	0..4	1	decimal point position for <b>u 15</b>
2	nDec	UINT	0..4	1	decimal point position on display
3	nTasti	UINT	0..0x151	0x111	button activation mode
4	Dir	UINT	0..1	0	count direction
5	Preset	DINT	-99999 +99999	0	Preset value
6	Loop	DINT	-99999 +99999	0	backlash compensation value
7	Positioning window	UINT	0..30000	10	target value tolerance

### 6.4.2.2 Position

#### Index: 4

This set contains exclusively the two useful positions of the device.

It is possible to reset the positions or preset them to a desired value by using acyclic access.

Indice parametro	Parametro	Tipo	Range	Accesso	Funzione
0	Position	DINT	-99999 +99999	R/W	Actual position of device
1	Target position	DINT	-99999 +99999	R/W	Target position of device

## 6.4.3 Ethercat address

The indicators of EP4 and F4 series allow the use of automatic addressing functions defined by the Ethercat protocol. However, it is still possible to set the Ethercat address using the ADDR parameter in the instrument's menu. In case the automatic addressing feature is used, leave ADDR at the default value (0).

# Digital position indicators with fieldbus – user manual

## 6.5 IO-Link communication protocol

EP4 and F4 implement the IO-Link protocol for IO-Device units. Communication consists of a cyclic part (*Status e Target*) and an acyclic part (*Parameters*).

To correctly associate EP4 and F4 devices with the appropriate IO-Link ProductFamily, please refer to the table below:

Codice	IO-Link device name	IO-Link device id
EP43NET	EP4NET	0x0111
EP46NET	EP4NET	0x0111
F4NET-AM	EP4NET	0x0111
F4NET-MT	F4NET	0x0112
F4NET-M12	F4NET	0x0112
F4NET-EM43	EP4NET	0x0111
F4NET-EM46	EP4NET	0x0111

The communication (I/O) part of the two product families is identical.

### 6.5.1 Cyclic communication (Process Data)

The cyclic communication of the EP4/F4 families is designed for the exchange of 10 input bytes and 4 output bytes. A punctual description of each byte is provided later on to make their understanding easier.

#### 6.5.1.1 Inputs (Slave → Master): 10byte, 5 word

Nome	Size (byte)	Tipo	Funzione
Status word	2	UINT	Word showing the device status (Status word table).
Actual position	4	DINT	Actual position
Actual target position	4	DINT	Target position which is currently shown on the display

## Digital position indicators with fieldbus – user manual

**Status word:** when moving from 0 to 1, each bit in this word warns about a different status of the device. The meaning of each status is explained below.

Bit	Nome	Descrizione
0	Ready	Device ready
1	Target reached	The current position is within the positioning window.
2	Battery low	The battery charge level is below a critical threshold: in this case it is necessary to substitute it within 15 days.
3	Battery fault	The battery is completely discharged, absent, or malfunctioning. In this case the battery must be immediately replaced because in this state it is not guaranteed that the instrument will be able to maintain the correct value when the 24VDC power supply is off. <b><u>NOTE: if this bit is present when the machine is turned on, it is necessary to execute a homing or reset procedure because the value measured by the EP4NET is no longer consistent with the actual position of the machine.</u></b>
4	Encoder fault	Internal encoder fault

### 6.5.1.2 Outputs (Master → Slave): 4 byte, 1 dword

Nome	Size (byte)	Tipo	Funzione
Target position	4	DINT	Target position to be shown on the display

## Digital position indicators with fieldbus – user manual

### 6.5.2 Acyclical communication (SDO)

The EP4 and F4 device uses two groups of acyclic parameters which contain the 11 parameters used for configuration.

All of the parameters can be modified in any moment.

For a more detailed description of the following parameters please refer to the *Programming* section.

Indice parametro	Parametro	Tipo	Accesso	Range	Default value	Funzione
80	Visual	UDINT	r/w	1..99999	<ul style="list-style-type: none"> <li>1000 (EP4)</li> <li>400 (F4)</li> </ul>	<ul style="list-style-type: none"> <li>value to be shown after one complete rotation of the shaft (EP4)</li> <li>value to be shown after 40mm displacement (F4)</li> </ul>
81	Visual decimal point	UINT	r/w	0..4	1	decimal point position for <b>u IS</b>
82	Number of decimal point	UINT	r/w	0..4	1	decimal point position on display
83	Buttons	UINT	r/w	0..0x151	0x111	button activation mode
84	Count direction	UINT	r/w	0..1	0	count direction
85	Preset position	DINT	r/w	-99999 +99999	0	Preset value
86	Backlash compensation	DINT	r/w	-99999 +99999	0	backlash compensation value
87	Positioning window	UINT	r/w	0..30000	10	target value tolerance
88	Battery	UINT	ro	-	-	To determine the battery status, refer to the bits of the status word.
89	Actual position	DINT	ro	-	-	Actual position
90	Actual target position	DINT	ro	-	-	Actual target position

### 6.5.3 System commands

The EP4 and F4 series, IO-Link version, also implement a series of system commands. The first three are standard for IO-Link networks and relate to various types of device reset. The command 0xA0 is instead necessary to perform the preset of the shown position, through the network master.

Valore comando	Nome	Funzione
0x80	Device reset	The device will be restarted. The IO-Link communication will be momentarily interrupted.
0x81	Application reset	The device will reset all parameters to their default values. Please note, after using this command, the calibration phase must be performed again.
0x83	Back to box	The device will reset all parameters to their default values and suspend the IO-Link communication. In case it is necessary to restore communication, a hardware reset of the device must be performed by disconnecting and reconnecting the power cable.
0xA0	Preset position to PRS0	By using this command, the value present in parameter 85 (Preset Position) will be set as the "Current Position". Please note, this command is not reversible.

# Digital position indicators with fieldbus – user manual

## 6.6 LEDs

Looking at the displays from the front (battery door side), from left to right, we have the following status LEDs: Link B, Network Status, Module Status, Link A.

Note: Communication LEDs are NOT available in the Modbus version.

LED Link-B	Profinet	Ethernet IP	Ethercat	Io-Link
Off	No connection / no power supply	No connection / no power supply	No connection / no power supply	No connection / no power supply
Green	Connection established - PORT 1	Connection established - PORT 1	Connection established - PORT 1	Encoder is in operational mode
Green flashing	Connection established and communication present - PORT 1	Connection established and communication present - PORT 1	Connection established and communication present - PORT 1	
LED Network Status				
Off	Connection with Profinet master not established	IP address is not set	Ethercat device in INIT mode	
Green	Master device is connected in RUN mode	Online, Ethernet-IP is connection is active	Ethercat device in OP mode	
Green flashing	Master device is connected in STOP mode	Online, Ethernet-IP is connection is not active	Ethercat device in PREOP mode	
Green flashing 2x	DCP Service	DCP service		
Red	Internal error	IP address fatal error (duplicate)		
Red flashing 1x	Profinet name not set	Ethernet-IP connection timed out		
Red flashing 2x	IP address not set			
Red flashing 3x	Configuration mismatch (GSDML)			
LED Module status-				
Off	No power supply	No power supply	No error	Io link inactive
Green	Profinet module is in operational mode	Network master connected and communication active		IO-Link connection is active
Green flashing	Diagnostic event	Communication is not active / Network master is In IDLE mode		
Red	Internal fatal error	Internal fatal error	Internal fatal error	IO-Link module is in error state
Red flashing 1x			Master configuration is not valid	
Red flashing 2x			Ethercat watchdog timeout	

## Digital position indicators with fieldbus – user manual

LED Link-A				
Off	No connection / no power supply	No connection / no power supply	No connection / no power supply	No connection / no power supply
Green	Connection established - PORT 1	Connection established - PORT 1	Connection established - PORT 1	
Green flashing	Connection established and communication present - PORT 0	Connection established and communication present - PORT 0	Connection established and communication present - PORT 0	Connection established and communication present

PORT 0: Right connector seen from connector front

PORT 1: Left connector seen from connector front



---

# Digital position indicators with fieldbus – user manual

## 6.7 Web server

The web server can be reached using the unit's IP address; to know and set the desired address, it is recommended to use one of the applications listed in the utility section.

Through the web server, you can configure all the parameters of the device. Additionally, in the DOC section, you can retrieve the user manuals of the instrument and the configuration files (GSDML/EDS).

Note: The web server is available ONLY in the Profinet and EthernetIP versions.

## 6.8 Utility

For the correct operation of the unit, it is essential to set the "device name" (in the Profinet version) and the IP address (in the Profinet and Ethernet IP versions) of the unit.

This can be done using the free Siemens Proneta software or by using Profinet Commander. Alternatively, you can use the HMS IPconfig software (only for setting the IP address).

## 7 Connection diagram

The following chapters contain the connection diagram for the various versions of EP4 and F4. Please refer ONLY to the version in use.

### 7.1.1 IO-Link version

- **POWER SUPPLY CONNECTOR**

M12x1 Male 4 pins A code, IO-Link code

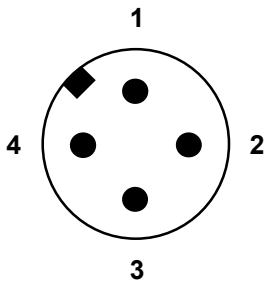

PIN	DESCRIPTION
1	+24VCC
2	NC
3	GND
4	IO-Link Data

# Digital position indicators with fieldbus – user manual

## 7.1.2 Modbus (RS) version

- POWER SUPPLY CONNECTOR 24VDC

M12x1 Male 4 pins A code, IO-Link code

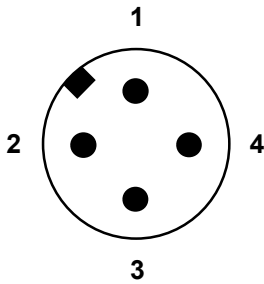

	CONNETTORE M12	CAVO
+10÷30VDC	1	BROWN
GND	2	WHITE
RS+ positive RS485 serial port	3	YELLOW
RS- negative RS485 serial port	4	GREEN
Not connected	-	GREY

View of the male 4-pole M12x1 connector.

The pin layout in both connectors is identical.

The termination resistor for the RS485 line (120 Ohms 1/4W) should be placed at the last node of the network by connecting it to pins 3-4 of the connector.

**Extreme caution is advised when making electrical connections: applying power to the pins of the serial port can damage the device.**

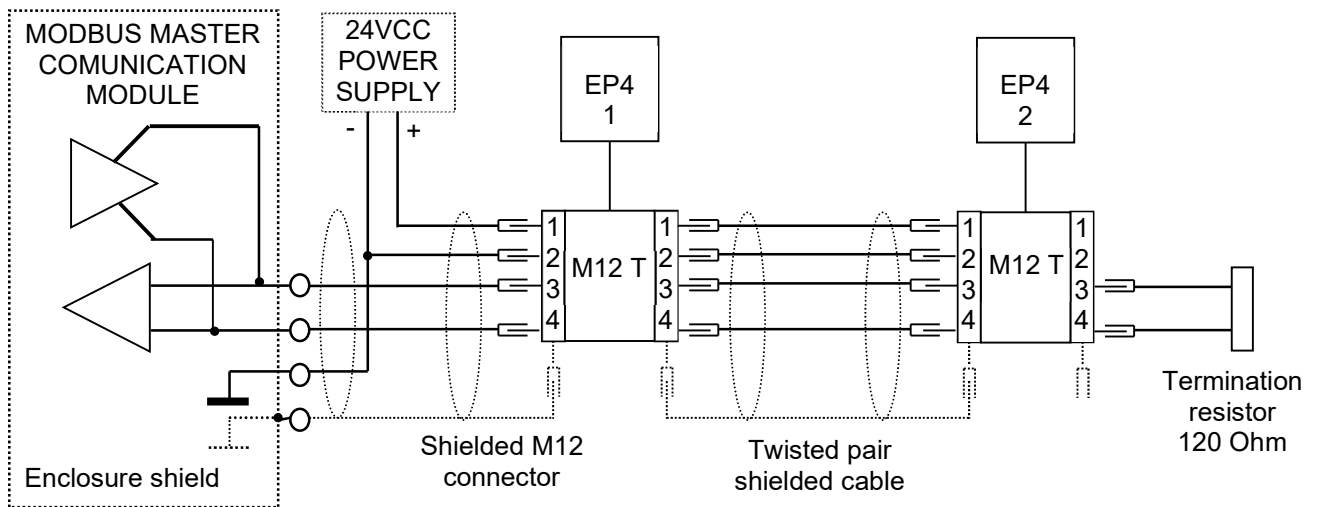

# Digital position indicators with fieldbus – user manual

## 7.1.3 Profinet/ EthernetIP/Ethercat versions

- **POWER SUPPLY CONNECTOR 24VDC**

M12x1 Male 4 pins A code

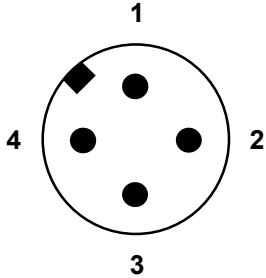

PIN	DESCRIPTION
1-4 (*)	GND
2-3 (*)	+24VDC

(\*) The two pins are internally connected together, and it is sufficient to wire only one of the two.

- **PROFINET/ETHERNET CONNECTOR**

M12x1 Female 4 pins D code (2 ports)

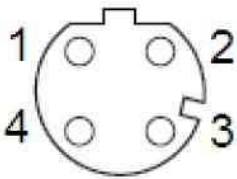

PIN	DESCRIPTION
1	TX DATA +
2	RX DATA +
3	TX DATA -
4	RX DATA -
CASE	CASE

Looking at the device with the battery cover door and the four LED indicators positioned at the top;  
Ethercat input: left connector  
Ethercat output: right connector

## 8 Display

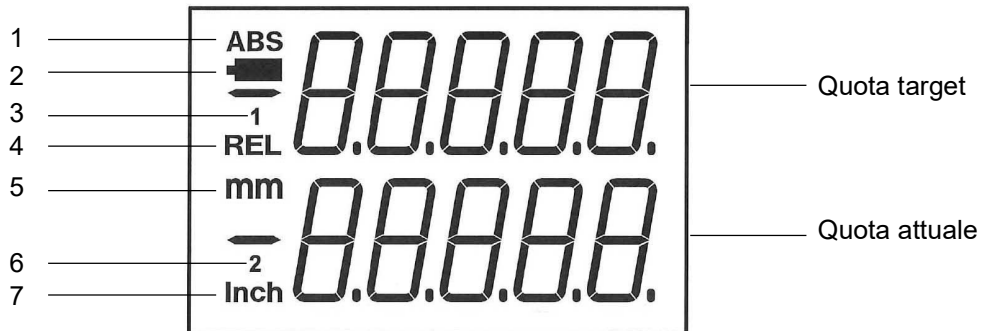

1. Absolute mode indicator
2. Low battery indicator: begins to blink when the level of charge is lower than a certain value and when it stays on is necessary to change the batteries within 15 days.
3. origin 1 indicator (not used)
4. Relative mode indicator
5. mm unit indicator
6. origin 2 indicator (not used)
7. inch unit indicator

### Error messages:

**ouEr** the current value exceeds the maximum value that can be visualized (from -99999 to 999999).

## 9 F4 sensors

### 9.1 Magnetic strip

The magnetic strip P50 consists of a magnetized plastic ferrite strip with alternate magnetic poles of 5 mm pitch, carried by a ferromagnetic steel strip. Mechanical protection of the plastic ferrite strip is supplied by a non magnetic steel strip with thickness 0,2mm.

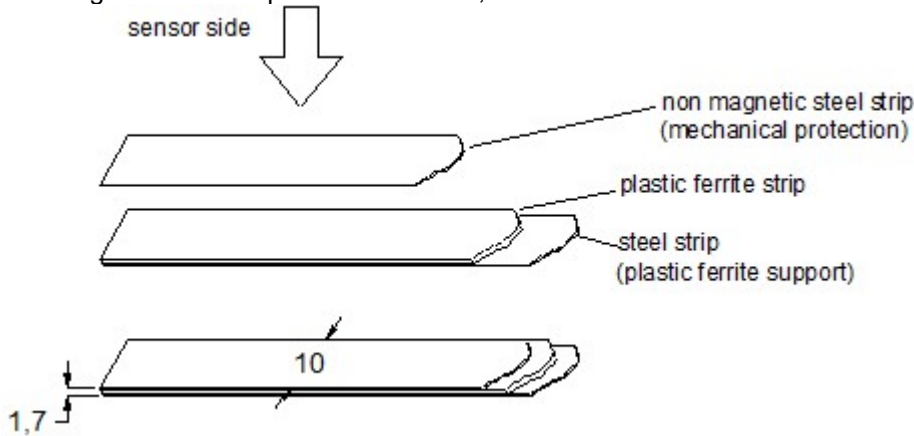

The magnetic strip is assembled by sticking it with a bi-adhesive tape. The surface has to be smooth, clean and dry: is advisable to clean it with a degreasing product (isopropyl alcohol, ethyl alcohol, solvents, etc). The magnetic strip has to be stuck holding the plastic ferrite side in the direction of the sensor, which means the steel side leaned on the stand surface. Fixed the magnetic strip, to keep off damages due to abrasions or grazes of the plastic ferrite strip, is advisable the appliance (always bi-adhesive) of the non magnetic protection strip. The optimal ambient temperature for stick the bi-adhesive tape is over 10°C. The maximum adherence of the tape works out after 48 hours (about) of the application and is kept between -10 and 80°C.

### 9.2 Linear sensor mounting

The sensor has to be mounted according to the following draw, and keeping the indicated tolerances. For the optimal system functioning it is necessary that the distance between the sensor and the magnetic band is not over 1mm of the useful stroke.

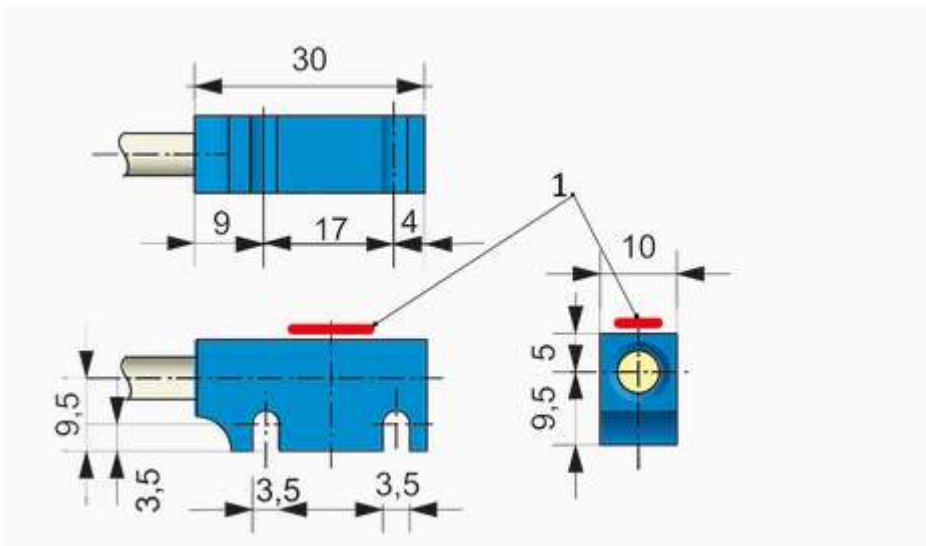
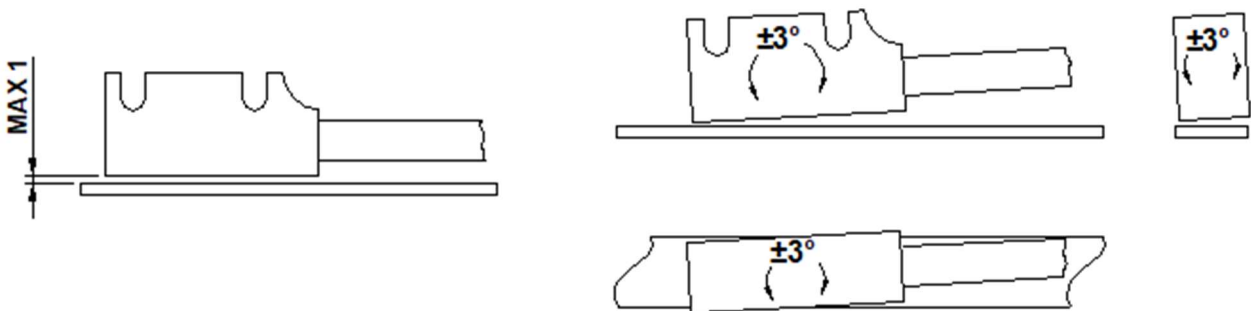

## 9.3 Magnetic ring mounting

(only F4 RS-AM and F4 NET AM)

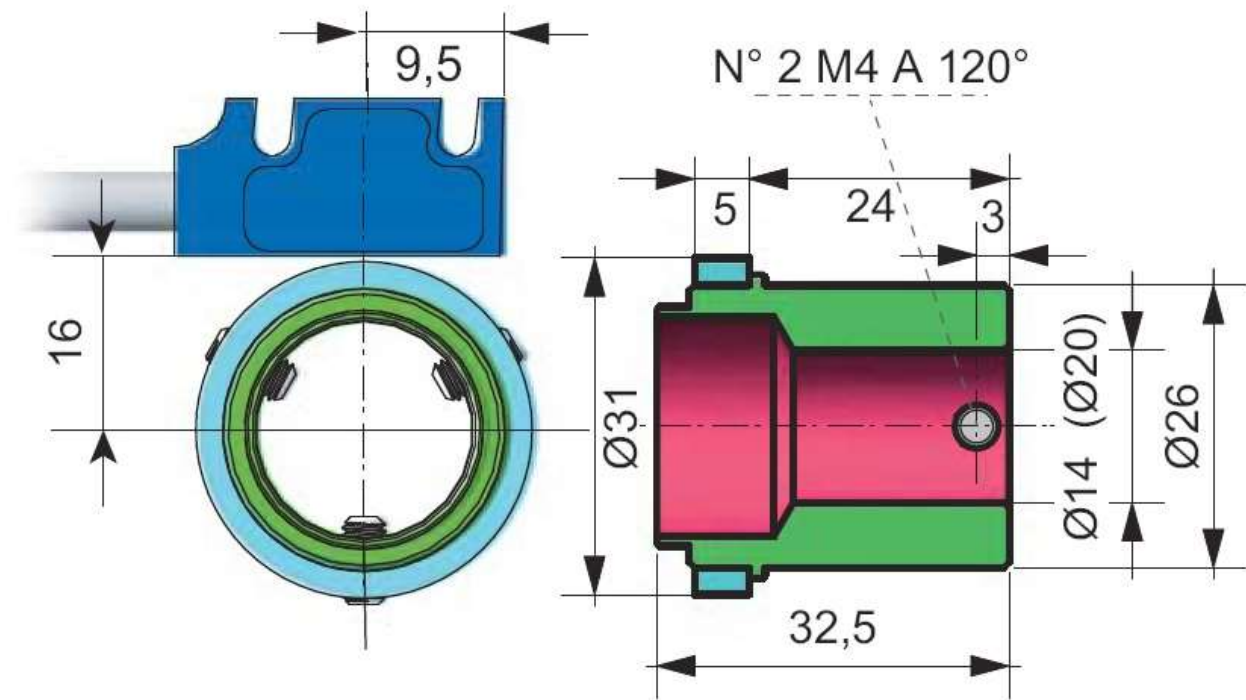

## 9.4 SM12 sensor mounting

(only F4 RS M12 and F4 NET M12)

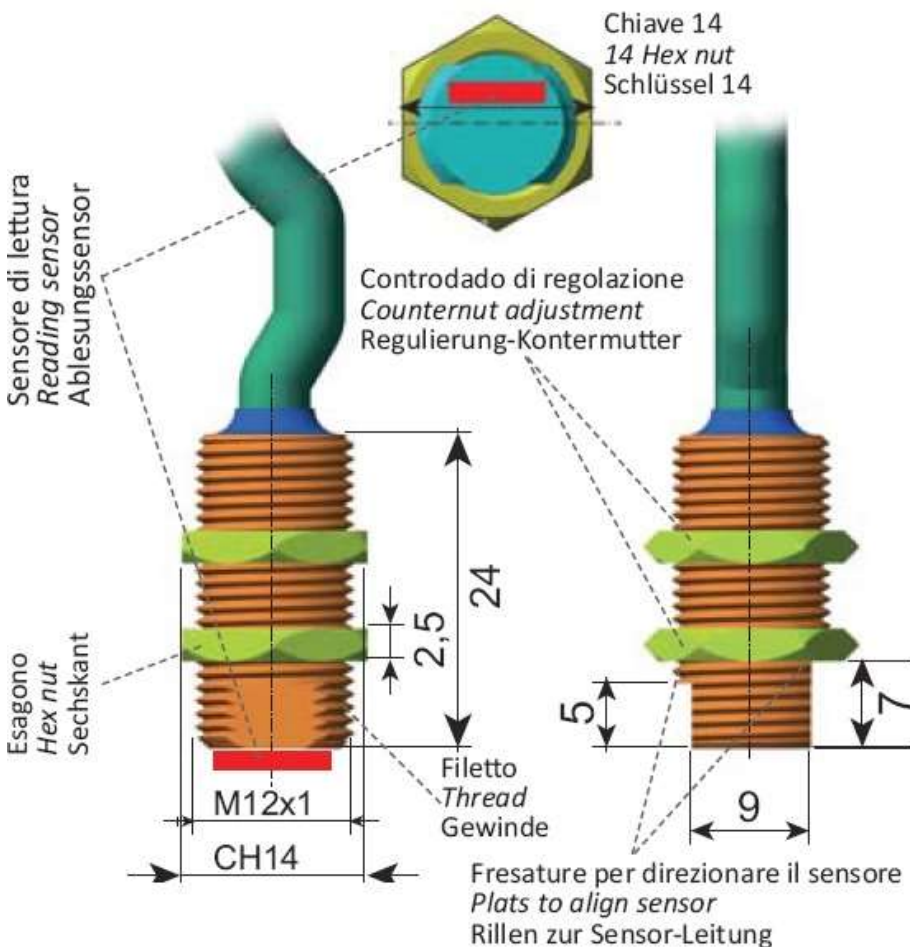

NB: the magnetic strip must be aligned parallel to the two lateral grooves of the sensor.

## 10 Serial RS485 modbus output connectors

(Only EP4xRS ed F4RS x versions)

### 10.1 M12T (standard) connector

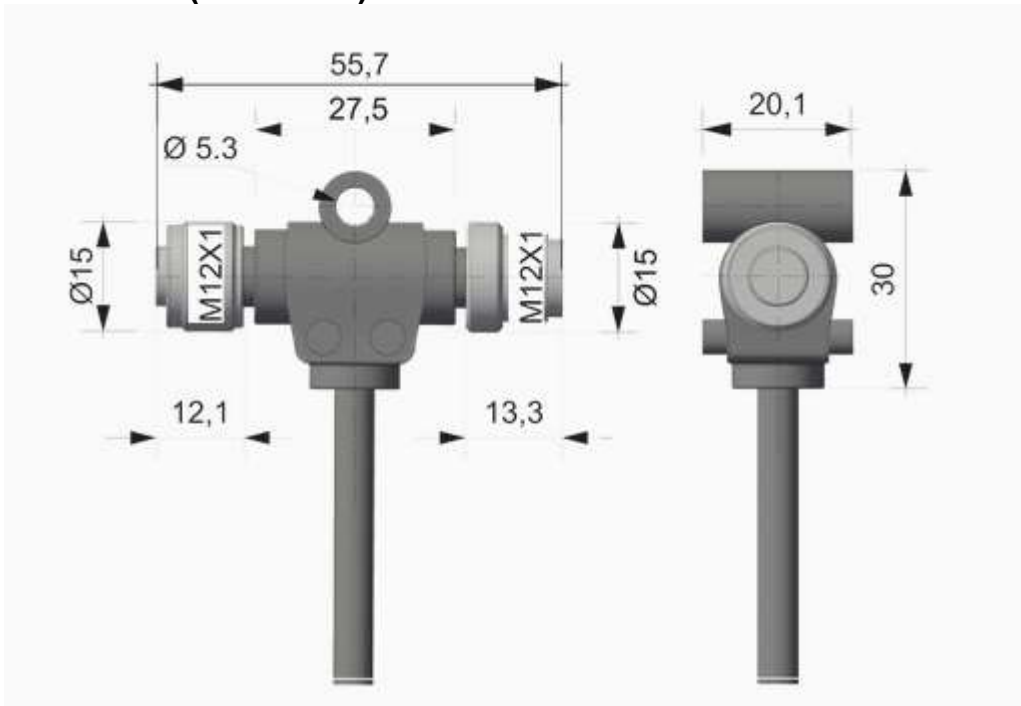

### 10.2 M12Y (optional) connector

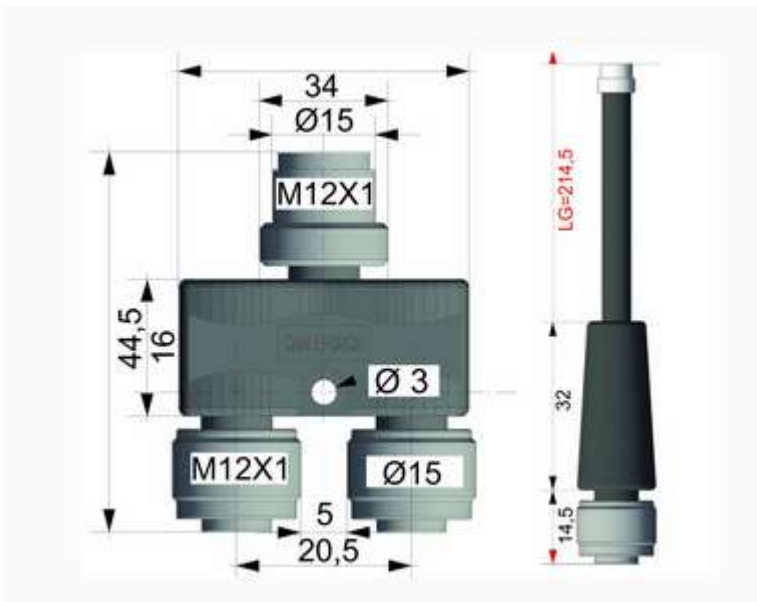



# Digital position indicators with fieldbus – user manual

## 11 Overall dimensions

### 11.1 EP43NET

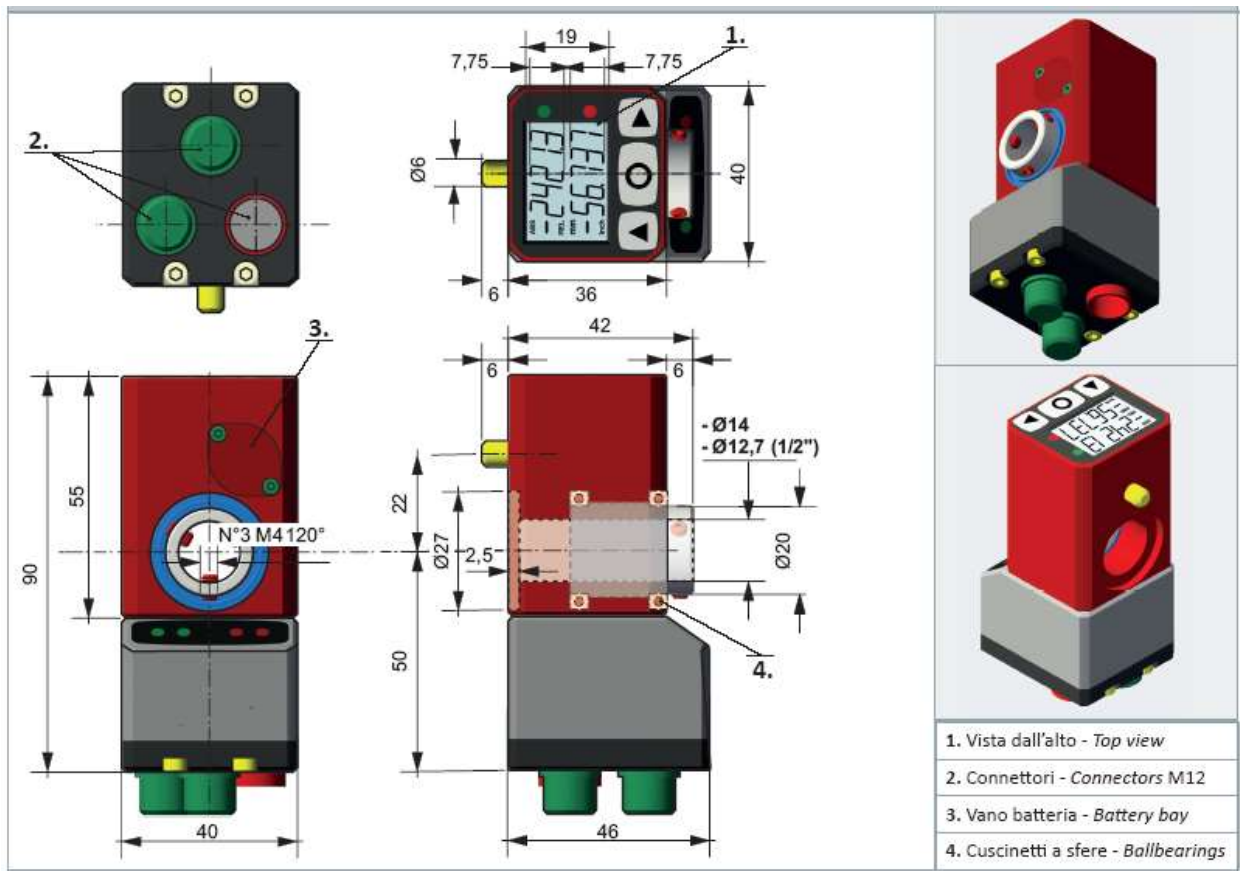

### 11.2 EP46NET

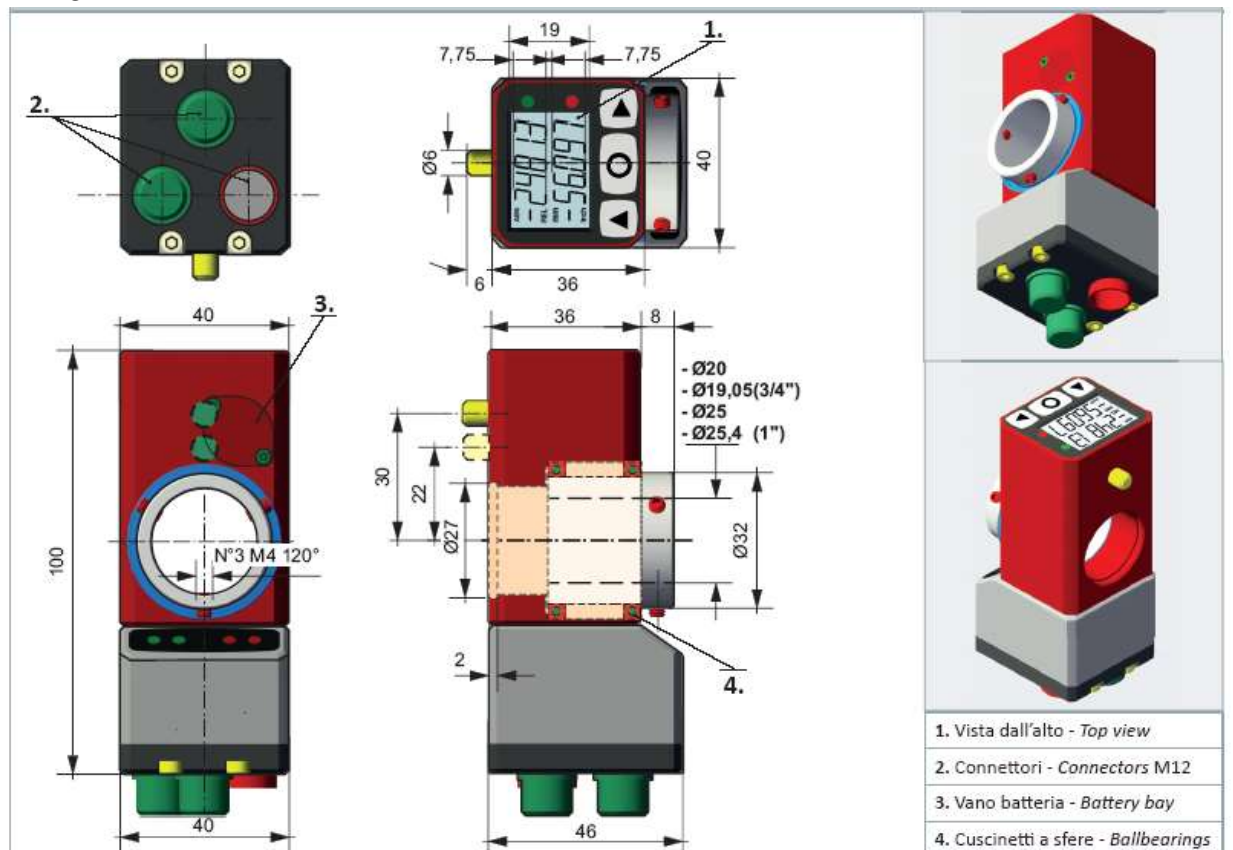

# Digital position indicators with fieldbus – user manual

## 11.3 EP43RS

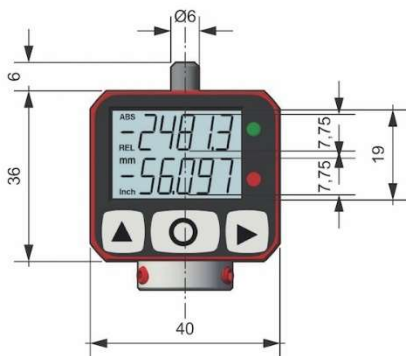
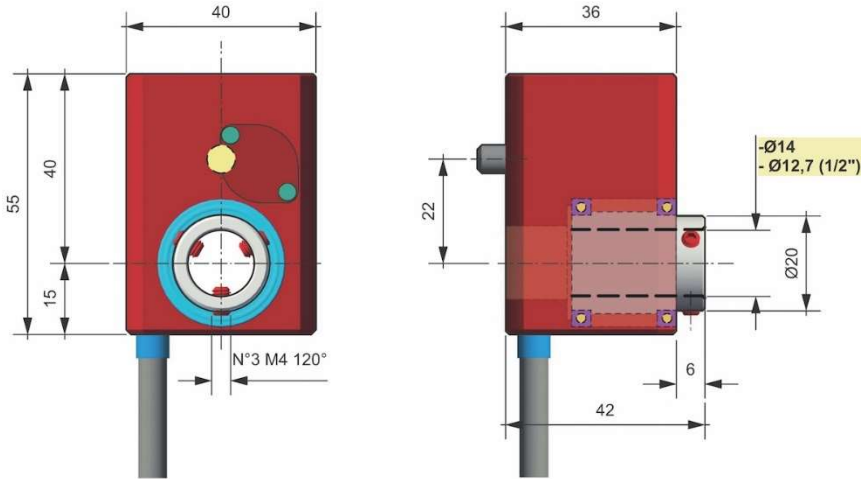

## 11.4 EP46RS

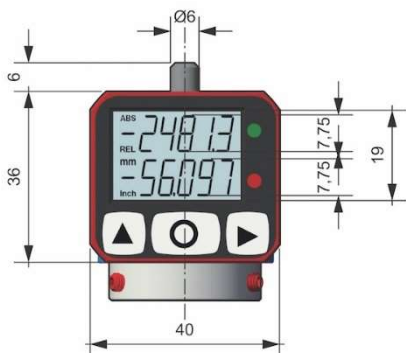
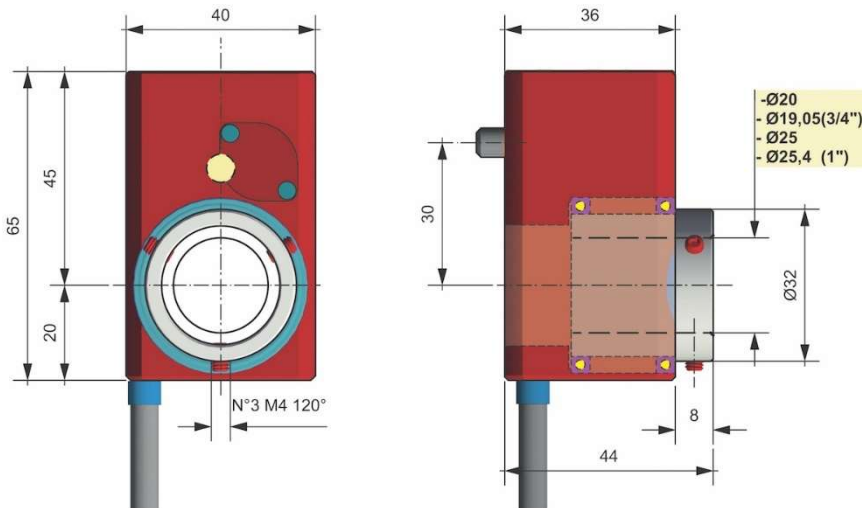



## 11.6 FANET

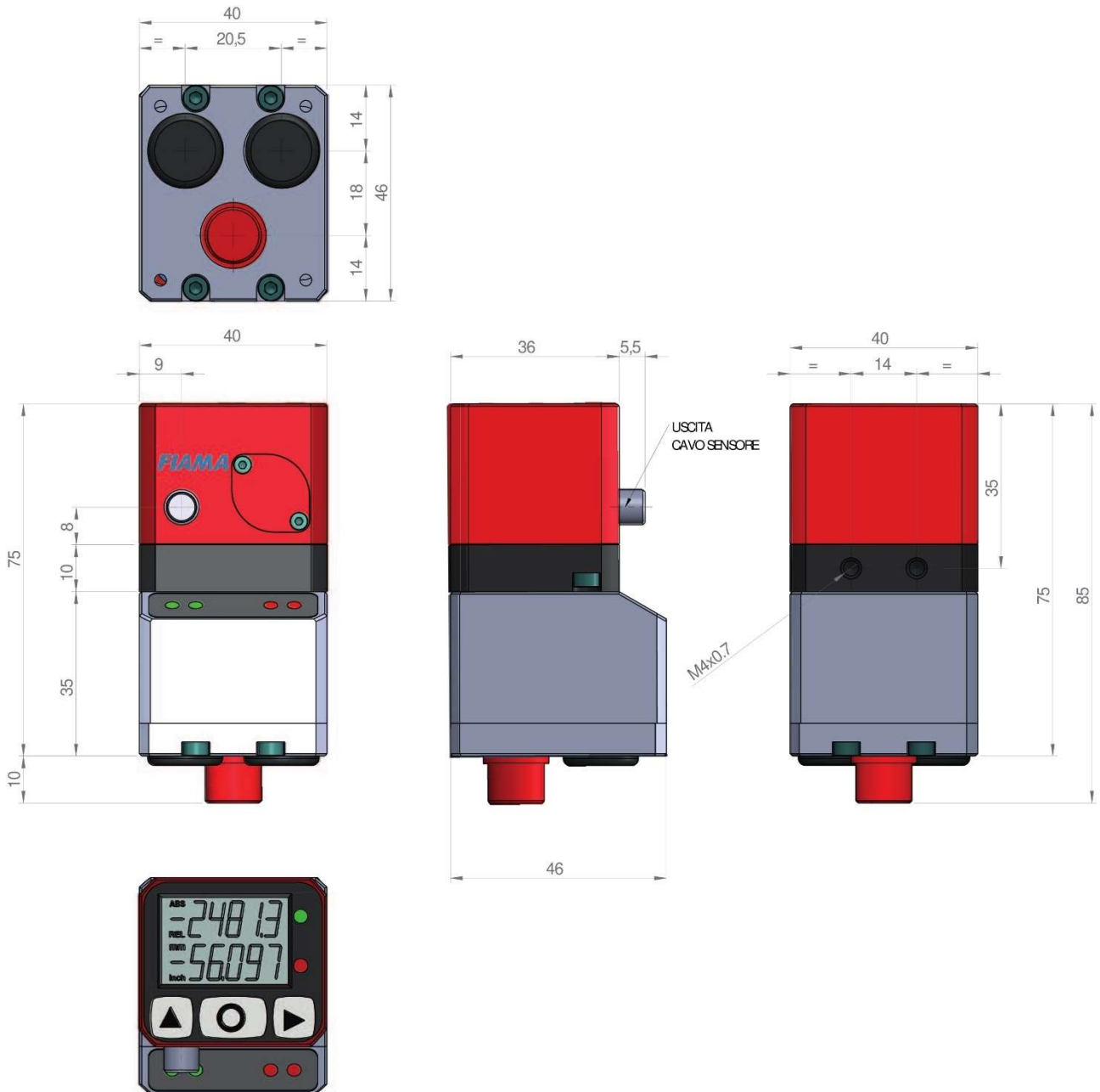

# Digital position indicators with fieldbus – user manual

## 12 Technical specifications

Power supply	10 - 30 Vdc max 100mA
Battery	3,6V 1/2 AA format life 6-8 years (depending on use conditions)
Hollow shaft diameter	EP43: Ø14, Ø1/2" EP46: Ø20, Ø3/4", Ø25
Max rotation speed	1000 RPM (magnetic ring) 2,5 m/s (magnetic strip)
Resolution	EP43NET: 3200 pulses/revolution EP46NET: 4000 pulses/revolution F4: 0.1mm
Range	-99999; 99999
Display	high readability LCD with 10mm-high-digits
Keyboard	3 digits for programming and function activation
Fieldbus	Profinet, EthernetIP, EtherCAT, Modbus, IOLink
Power supply connector (EP4NET ed F4NET)	Male M12x1 - 4 pin A code
Ethernet connector (Profinet EthernetIP Ethercat)	2x Female M12x1 - 4 pin D code
Serial output protocol (EP4RS and F4RS)	RS485 MODBUS RTU
Serial port connector (EP4RS ed F4RS)	M12T: 4 pin male + 4 pin female. M12x1 cod. A M12Y: 4 pin female + 2x M12x1 4 pin male code A
F4 sensor cable (provided pre-wired and non-detachable from the device)	Available lengths: 0,5 – 1 – 3 – 5 meters Material: PUR Ø5,5mm suitable for movable wiring cable
F4 sensor housing	IP67 - Alluminium black
Maximum distance between sensor and magnetic strip (F4)	1mm max
Available functions	reset/preset, absolute/incremental value, mm/inch conversion, 3 distinct origins for tool changing
IP protection	IP65
Working temperature	0-50°C
Relative humidity	35-85%
Electromagnetic compatibility	2014/30/UE
RoHS	2011/65/UE
EMC	2014/30/UE

## **13 Manufacturer**

All communications to the manufacturer should be addressed to:

FIAMA s.r.l., Via G. Di Vittorio, 5/A – 43016 San Pancrazio (Parma) - Italy

Tel. (+39) 0521.672.341 – Fax. (+39) 0521.672.537 – e-mail: [info@fiama.it](mailto:info@fiama.it) – [www.fiama.it](http://www.fiama.it)

**FIAMA srl is not responsible for any damage to persons or things caused by tampering and improper use and in any cases that are not compatible with the features of the instrument.**

